

# Orange County Stormwater Low Impact Development Manual Volume 2



*Submitted by:*  
**Geosyntec Consultants, Inc.**  
3504 Lake Lynda Drive, Suite 155  
Orlando, Florida 32817

**December 2023**

**Geosyntec**   
consultants

engineers | scientists | innovators

# STORMWATER LOW IMPACT DEVELOPMENT MANUAL

## Volume 2

*Prepared for:*

**Orange County Planning Division**

201 S. Rosalind Ave., 2<sup>nd</sup> Floor  
Orlando, FL 32802

**Orange County Public Works**

4200 S John Young Parkway  
Orlando, FL 32839

**Orange County Environmental Protection Division**

3165 McCrory Place, Suite 200  
Orlando, FL 32803

*Prepared by:*

Geosyntec Consultants, Inc.  
3504 Lake Lynda Drive, Suite 155  
Orlando, FL 32817

Project Number: FW8213

December 2023

Revision Section	Date
Draft	02/07/2023
Final	12/28/2023

## **ACKNOWLEDGEMENTS**

The developers of this Manual acknowledge the vision and work of local governments that guided the effort of the development of this Manual. We would like to acknowledge, in particular, support from the following individuals for their contributing to the creation of this Manual:

### **Orange County**

Jennifer Cummings (Project Manager) – Public Works Department

Julie Bortles (Environmental Programs Administrator) – Environmental Protection Division

Roberto Ng (Senior Engineer) – Public Works Department

Olan Hill (Assistant Manager) – Planning Division

Jennifer Thomson (NPDES Program Supervisor)

### **Geosyntec Team**

Mark Ellard (Senior Principal)

Mike Hardin (Principal Engineer)

Jovana Radovanovic (Staff Scientist)

Cathy Foerster (Senior Professional)

Eric Davis (Senior CADD/Drafting Tech)

Kenneth Hamilton (Senior Staff Professional)

Ruth Hamberg (Landscape Architect) – Alliance Design & Construction, Inc.

## TABLE OF CONTENTS

1. BACKGROUND AND MANUAL ORGANIZATION .....	1-1
1.1 Purpose and Scope.....	1-1
1.2 General Introduction to LID.....	1-1
1.3 Organization and Intended Users .....	1-1
1.4 Definitions .....	1-2

## LIST OF ATTACHMENTS

- Attachment 1: Bioretention Design Details, Operation, and Maintenance
- Attachment 2: BAM Enhancements Design Details, Operation, and Maintenance
- Attachment 3: Tree Box Filters Design Details, Operation, and Maintenance
- Attachment 4: Infiltration Planter Boxes Design Details, Operation, and Maintenance

## ACRONYMS AND ABBREVIATIONS

BAM	Biosorption Activated Media
BMAP	Basin Management Action Plan
BMP	Best Management Practice
CEC	Cation Exchange Capacity
DCIA	Directly Connected Impervious Area
DEM	Digital Elevation Model
EMC	Event Mean Concentration
EPA	Environmental Protection Agency
ERP	Environmental Resource Permit
FAC	Florida Administrative Code
FDEP	Florida Department of Environmental Protection
GSI	Green Stormwater Infrastructure
H&H	Hydrologic and Hydraulic Modeling
ICPR4	Interconnected Channel and Pond Routing Model
LID	Low Impact Development
MS4	Municipal Separate Storm Sewer System
N <sub>2</sub>	Nitrogen Gas
NH <sub>3</sub>	Ammonia
NO <sub>2</sub>	Nitrite
NO <sub>3</sub>	Nitrate
NOAA	National Oceanic and Atmospheric Administration
NPDES	National Pollutant Discharge Elimination System
NWL	Normal Water Level
OFS	Outstanding Florida Springs
OFW	Outstanding Florida Waters
PFA	Primary Focus Area
RAP	Reasonable Assurance Plan
SFWMD	South Florida Water Management District
SJRWMD	St. Johns River Water Management District
SWMM	Storm Water Management Model
SWMP	Stormwater Management Program

Tc	Time of Concentration
TMDL	Total Maximum Daily Load
TN	Total Nitrogen
TP	Total Phosphorus
UF/IFAS	University of Florida/Institute of Food and Agricultural Sciences
VBS	Vegetated Buffer Strips
WERF	Water Environment Research Foundation
WMD	Water Management District

## 1. BACKGROUND AND MANUAL ORGANIZATION

This section states the purpose of Volume 2 of the Design Manual and a breakdown of the sections and general manual organization. It also identifies the intended users for this manual and defines commonly used terms and abbreviations.

### 1.1 Purpose and Scope

Volume 2 of the Design Manual is intended to provide technical guidance and design specifications on Low Impact Development (LID) stormwater management practices for projects in Orange County, Florida. Volume 2 takes into consideration different conditions throughout the County that may affect different LID practices and goes over practices that are applicable to Orange County. Design, operation, and maintenance guidance are provided, as well as design details for selected practices. It is noted that while the focus of this volume is structural LID practices, non-structural LID practices should always be considered prior to, and in conjunction with, structural practices.

### 1.2 General Introduction to LID

LID is a stormwater management approach that uses a suite of hydrologic controls (structural and non-structural) distributed throughout the site and integrated as a treatment train (i.e., in series) to replicate the natural hydrologic function of the landscape. The most important LID practices are non-structural which promote proper site development and working with the natural environment. It should be noted that LID includes both non-structural and structural practices which work together to reduce the impact of developed areas and promote natural movement of water within an ecosystem. Volume 2 of this manual focuses on structural practices. This is complementary to Section 2 in Volume 1 of this manual that presents non-structural LID practices which should be reviewed and implemented as a first line of defense.

Unlike conventional systems, which typically control and treat runoff using a single engineered stormwater pond located at the “bottom of the hill,” LID systems are designed to promote volume attenuation and treatment at or near the source of stormwater runoff via distributed retention, detention, infiltration, treatment, and harvesting mechanisms. The fundamental goal of applying LID concepts, designs, and practices is to improve the overall effectiveness and efficiency of stormwater management systems. Incorporation of LID can reduce total and peak runoff volumes and improve the quality of water discharged from the site.

### 1.3 Organization and Intended Users

This volume of the Design Manual is organized into separate attachments that provide more specific information for structural LID practices that have been shortlisted from the Volume 1 evaluation. This includes bioretention systems, BAM enhancements, tree box filters, and infiltration planter boxes. Design details, operation and maintenance guidelines, and monitoring guidance are included for each practice. It is intended to be used primarily by professionals engaged in planning, designing, constructing, operating, and maintaining development and retrofit projects in Orange County, Florida. The attachments include the following:



- **Attachment 1** – Bioretention
- **Attachment 2** – BAM Enhancements
- **Attachment 3** – Tree Box Filters
- **Attachment 4** – Infiltration Planter Boxes

It is noted that, while this manual and the included calculations are focused on water quality, the LID practices discussed in the manual can also provide attenuation for flood control which should be factored into site design.

## 1.4 Definitions

As some terms related to stormwater are used interchangeably in the industry, the following definitions are provided for clarification and better understanding of how these terms are used in this manual. A prime example of this are the terms Low Impact Development (LID), Green Stormwater Infrastructure (GSI), and Best Management Practices (BMP). For the purposes of this manual, LID and GSI are assumed to be a type of BMP used to treat and/or attenuate stormwater runoff. See below for definitions of terms used in this manual.

- **Average Annual Runoff Coefficient:** The average ratio of runoff depth to precipitation depth over an extended period of time, usually 15 years or greater, normalized by the total numbers of years to obtain an average annual value.
- **Bacteria:** Historically, regulations based on bacteria focused primarily on fecal coliforms. In 2016, FDEP, and thus Orange County and this Manual, switched to *E. coli* for freshwater systems.
- **Basin Management Action Plan (BMAP):** A BMAP is a framework for water quality restoration that contains local and state commitments to reduce pollution loading through current and future projects and strategies. The pollutant reduction goals are ones previously established by a total maximum daily load (TMDL).
- **Best Management Practice (BMP):** For the purposes of this manual, a BMP is any structural or non-structural practice that results in the capture, treatment, and/or attenuation of stormwater runoff. This includes practices that leverage retention, detention, and infiltration processes for flood reduction, as well as various physical, biological, and chemical processes for water quality improvement.
- **Biosorption Activated Media (BAM):** A class of filter media that promotes biofilm growth and leverages biological, chemical, and physical processes to remove nitrogen and phosphorus species. The media can range from coarse material, intended for higher flow capacity, or finer material, intended for slower flow applications, such as for use in the bottom of a retention BMP.
- **Curve Number (CN):** CN is the hydrologic factor which is used to reflect the runoff potential of a particular land use and soil type. Values for CN range from 30-100, with low values reflecting a low runoff potential and higher values reflecting a high runoff potential.

- **Directly Connected Impervious Area (DCIA):** DCIA is the impervious area that is directly connected to a drainage feature, i.e., if runoff from the area flows directly into the drainage conveyance system, such as a gutter or storm sewer, and does not drain to a pervious area (Harper and Baker, 2007). Runoff from impervious area must run over a minimum of 20 ft of pervious area to be considered disconnected.
- **Drainage Area:** An area where runoff from precipitation drains to a common point, i.e., creeks, streams, rivers, lakes, and reservoirs. The perimeter of a drainage area can be identified using topographic and drainage infrastructure maps to determine the boundary between where runoff would and would not flow to the collection point or drainage area outlet.
- **Gray Infrastructure:** Refers to engineered infrastructure for water resources, typically consisting of concrete and metal components. Examples include treatment plants, pipes, and reservoirs. In gray infrastructure, runoff is directed away from certain locations and towards others.
- **Green-Ampt Method:** The Green-Ampt method is a rainfall excess estimation method that leverages the physical characteristics of soils to determine the fraction of rainfall that infiltrates into the ground, is stored in the soils, and becomes stormwater runoff. This rainfall excess estimation method can be used for either discrete design storm modeling or continuous simulation modeling but is generally needed for a continuous simulation as opposed to other methods as it allows for the long-term tracking of soil water storage availability.
- **Green Stormwater Infrastructure (GSI):** GSI consists of structural practices that incorporate the principals of LID to trap and treat stormwater near its source, minimizing the quantity, and improving the quality of stormwater discharging to gray stormwater infrastructure and downstream water resources. GSI can be used in place of, or in conjunction with, traditional gray infrastructure.
- **Horizon West Town Center:** Located in the southwest portion of Orange County, Horizon West Town Center is comprised of more than 23,000 acres encompassing five Villages and a 3,500 acre Town Center. The area was identified as an opportunity to evaluate the use of LID practices in an urban environment where the benefits and costs of the more sustainable water resource management systems can be measured and quantified.
- **Infrequent Maintenance:** Refers to maintenance that occurs a few times during the life of the practice, such as repairs or replacements.
- **Interconnected Channel and Pond Routing (ICPR):** ICPR is a hydrologic and hydraulic modeling tool with a focus on interconnected and interdependent pond systems. The author of this modeling tool is Streamline Technologies and it is proprietary.
- **Karst:** Karst describes areas underlain by carbonate rocks, primarily limestone and dolomite. Karst formation involves the chemical weathering and erosion of carbonate rocks and is characterized by sinkholes and caves.

- **Low Impact Development (LID):** LID is an approach to land development (or re-development) that works with nature to manage stormwater as close to its source as possible. LID employs principles such as preserving and recreating natural landscape features, minimizing effective imperviousness to create functional and appealing site drainage that treat stormwater as a resource rather than a waste product.
- **New Development:** Construction on sites that were previously greenfield areas; no previous construction or development were present.
- **Non-Directly Connected Impervious Area (Non-DCIA):** Non-DCIA includes impervious areas which are not considered to be directly connected to drainage infrastructure. This is defined as having a flow distance of at least 20 feet of pervious area that runoff would have to flow over prior to discharge into a drainage conveyance. Runoff generated from these areas can infiltrate into the soil depending on soil types and land cover characteristics reducing the runoff volume from these areas compared to impervious areas directly connected.
- **Non-Directly Connected Impervious Area Curve Number (Non-DCIA CN):** The non-DCIA CN includes pervious and impervious areas that are not directly connected to a drainage conveyance. It is calculated by using the open space reference in the TR-55 document for pervious areas and using 98 for non-DCIA impervious areas. Then, the area-weighted average is calculated. A common mistake that occurs when calculating the non-DCIA CN is double counting the impervious areas, which occurs when using one of the TR-55 reference land use values, other than open space, for the non-DCIA CN as this value includes the DCIA.
- **Outstanding Florida Springs (OFS):** Section 373.802(4), Florida Statutes (F.S.), defines “Outstanding Florida Springs” or “OFS” to include all historic first magnitude springs, as determined by the department using the most recent Florida Geological Survey springs bulletin, and the following additional six springs: DeLeon, Peacock, Poe, Rock, Wekiva, and Gemini. OFS do not include submarine springs or river rises. There are 30 OFS consisting of 24 historic first magnitude springs and the 6 named additional springs.
- **Outstanding Florida Waters (OFW):** An OFW is a waterbody deemed worthy of special protection because of its natural attributes (e.g., excellent water quality or exceptional ecological, social, educational, or recreational value). Waters are designated OFW to prevent the lowering of existing water quality due to permitted activities and to preserve the exceptional ecological and recreational significance of the waterbody. It is worth noting that these have additional regulatory requirements.
- **Peaking Factors:** Peaking factor is the ratio of the maximum flow to the average daily flow of a system (Zhang et al., 2012). Peaking factors are a hydrologic and hydraulic (H&H) modeling parameter.
- **Pre-developed Land:** The land use condition currently existing prior to any new improvements. This can include an undeveloped condition or an improved condition such as pasture or a previously constructed building or other improvement.

- **Redevelopment:** Construction on sites having existing commercial, industrial, institutional, or residential land uses, excluding silviculture or agriculture, where all or part of the existing impervious surface will be replaced with the same or lesser intense land use as part of the proposed activity and has not been previously permitted under Part IV of Chapter 373 F.S.
- **Regular Maintenance:** Refers to annual/semi-annual/monthly practice upkeep, such as mowing, debris removal, pruning, and weeding.
- **Runoff Coefficient (C):** The runoff coefficient represents the ratio of runoff depth to the precipitation depth. This value can be calculated on either an event basis or for an annual period.
- **Seasonal High Groundwater Table (SHGWT):** The SHGWT represents the average high elevation of the groundwater table during the wet season. SHGWT determination should be in line with the State requirements, which states that “estimates are completed using generally accepted engineering and scientific principles which reflect drainage practices, average wet seasonal water table elevation, antecedent moisture, and any underlying soil characteristics that would limit or prevent percolation of stormwater through the entire soil column.” For determining seasonal highs in wetlands and surface waters: A qualified scientist shall determine the seasonal high in wetlands and surface waters by utilizing the States requirements. The average surveyed wetland contour line may be used in lieu of the seasonal high for the purposes of setting a tailwater condition for modeling.
- **Soil Survey Geographic Database (SSURGO):** A database that contains information about soil as collected by the National Cooperative Soil Survey over the course of a century. The information was gathered by walking over the land and observing the soil. Many soil samples were analyzed in laboratories. The SSURGO database reports physical and chemical properties of soils that are necessary for some modeling approaches, such as the Green-Ampt method of runoff estimation. It is worth noting that mapped soils may not reflect actual conditions, particularly in urban and peri-urban areas. Any soils properties used in engineering design should always be confirmed on-site by a licensed geotechnical professional engineer.
- **Special Basins:** Basins that are draining to an OFW, OFS, or other waterbodies that warrant extra levels of treatment. This is done to protect against degradation of already impaired waterbodies or protect healthy/pristine waterbodies from degradation.
- **Storm Water Management Model (SWMM):** SWMM is an H&H modeling tool used for planning, analysis, and design related to stormwater runoff, combined and sanitary sewers, and other drainage systems. The author of this modeling tool is the EPA and it is non-proprietary.
- **Stormwater Runoff:** Stormwater runoff is the fraction of rainfall that does not evaporate, get absorbed by vegetation, and/or infiltrates into the ground. Stormwater runoff picks up pollutants such as nutrients, trash, and sediments, as it flows over land surfaces.
- **Time of Concentration (Tc):** Tc refers to the amount of time it takes for a single drop of water to travel from the hydraulically most distant point in a drainage area to the outlet.

- **Total Maximum Daily Load (TMDL):** A TMDL is the calculation of the maximum amount of a pollutant allowed to enter a waterbody so that the waterbody will meet and continue to meet water quality standards for a given pollutant. A TMDL determines a pollutant reduction target and allocates load reductions necessary to the source(s) of the pollutant of concern. BMAPs are the plans for implementing TMDLs.
- **Total Nitrogen (TN):** TN is made up of ammonium ( $\text{NH}_4$ ), nitrite ( $\text{NO}_2$ ), nitrate ( $\text{NO}_3$ ), and particulate and dissolved organic forms of nitrogen.  $\text{NH}_4$ ,  $\text{NO}_2$ , and  $\text{NO}_3$  are dissolved forms of nitrogen. In this manual, nitrogen will be referred to as TN, unless nitrogen species are stated explicitly.
- **Total Phosphorus (TP):** TP is made up of particulate phosphorus and dissolved phosphorus. In this manual, phosphorus will be referred to TP, unless phosphorus species are stated explicitly.
- **Total Suspended Solids (TSS):** TSS is a measure of the small particles of solid pollutants in waterbodies. Solids may originate from many sources, including erosion from pervious surfaces, dust, litter, and other particles deposited on impervious surfaces from human activities or the atmosphere (EPA, 1999).
- **Undeveloped Land:** As referred to in this manual, this refers to the natural state of a piece of land prior to human modification. This is to include physical properties such as soils, topography, vegetative communities, and animal communities and chemical properties such as EMCs.

# **ATTACHMENT 1**

## **Bioretention**



engineers | scientists | innovators



# STORMWATER LOW IMPACT DEVELOPMENT MANUAL, VOLUME 2

## ATTACHMENT 1

# BIORETENTION

*Prepared for*

**Orange County Planning Division**  
201 S. Rosalind Ave., 2<sup>nd</sup> Floor  
Orlando, FL 32802

**Orange County Public Works**  
4200 S John Young Parkway  
Orlando, FL 32839

**Orange County Environmental Protection Division**  
3165 McCrory Place, Suite 200  
Orlando, FL 32803

*Prepared by*

Geosyntec Consultants, Inc.  
3504 Lake Lynda Drive, Suite 155  
Orlando, FL 32817

Project Number: FW8213

December 2023

## TABLE OF CONTENTS

1. BACKGROUND .....	1-1
1.1 Design Features of Typical System.....	1-1
1.2 Design Guidance and Criteria .....	1-3
1.3 Site Suitability .....	1-5
1.4 Pollutant Removal Efficiencies .....	1-6
1.5 Regulatory and Permitting Considerations.....	1-6
1.6 Construction Considerations .....	1-7
1.7 Design Details and Specifications .....	1-7
1.8 Artist Renderings.....	1-10
1.9 Inspection, Maintenance, and Monitoring.....	1-10
1.9.1 Inspection Steps and Checklists for Bioretention Systems without Underdrains .....	1-11
1.9.2 Water Quality Performance Monitoring Guidance for Bioretention Systems without Underdrains .....	1-13
1.9.3 Inspection Steps and Checklists for Bioretention Systems with Underdrains .....	1-13
1.9.4 Water Quality Performance Monitoring Guidance for Bioretention Systems with Underdrains .....	1-16
1.10 Design Calculations Example for Well-Draining Sandy Soils .....	1-16
1.11 Design Calculations Example for Poor-Draining / High Water Table Soils or Sensitive Groundwater Areas.....	1-18

## LIST OF TABLES

Table 1-1. Porosity of Materials used in Bioretention Areas.....	1-4
--	-----

## LIST OF FIGURES

Figure 1-1: Bioretention with Deep Groundwater Table Details.....	1-8
Figure 1-2: Bioretention with Shallow Groundwater Table Details.....	1-9
Figure 1-3: Bioretention System in an Urban Landscape Setting.....	1-10



## **LIST OF APPENDICIES**

- Appendix 1A: Bioretention without Underdrains Operation and Maintenance Checklist
- Appendix 1B: Bioretention without Underdrains Operation and Maintenance Flow Chart
- Appendix 1C: Bioretention without Underdrains Water Quality Monitoring Guidance
- Appendix 1D: Bioretention with Underdrains Operation and Maintenance Checklist
- Appendix 1E: Bioretention with Underdrains Operation and Maintenance Flow Chart
- Appendix 1F: Bioretention with Underdrains Water Quality Monitoring Guidance

## ACRONYMS AND ABBREVIATIONS

BAM	Biosorption Activated Media
BMAP	Basin Management Action Plan
BMP	Best Management Practice
CEC	Cation Exchange Capacity
DCIA	Directly Connected Impervious Area
DEM	Digital Elevation Model
EMC	Event Mean Concentration
EPA	Environmental Protection Agency
ERP	Environmental Resource Permit
FAC	Florida Administrative Code
FDEP	Florida Department of Environmental Protection
GSI	Green Stormwater Infrastructure
H&H	Hydrologic and Hydraulic Modeling
ICPR4	Interconnected Channel and Pond Routing Model
LID	Low Impact Development
MS4	Municipal Separate Storm Sewer System
N <sub>2</sub>	Nitrogen Gas
NH <sub>3</sub>	Ammonia
NO <sub>2</sub>	Nitrite
NO <sub>3</sub>	Nitrate
NOAA	National Oceanic and Atmospheric Administration
NPDES	National Pollutant Discharge Elimination System
NWL	Normal Water Level
OFS	Outstanding Florida Springs
OFW	Outstanding Florida Waters
PFA	Primary Focus Area
RAP	Reasonable Assurance Plan
SFWMD	South Florida Water Management District
SJRWMD	St. Johns River Water Management District
SWMM	Storm Water Management Model

SWMP	Stormwater Management Program
Tc	Time of Concentration
TMDL	Total Maximum Daily Load
TN	Total Nitrogen
TP	Total Phosphorus
UF/IFAS	University of Florida/Institute of Food and Agricultural Sciences
VBS	Vegetated Buffer Strips
WERF	Water Environment Research Foundation
WMD	Water Management District

## 1. BACKGROUND

This attachment provides detailed information on bioretention/rain garden design. It is noted that, for the purposes of this manual, bioretention and rain garden are interchangeable, however, hereafter this manual will use the term bioretention. Design features of typical systems, as well as design guidance and criteria, are presented and discussed. Additionally, site suitability, pollutant removal efficiencies, regulatory and permitting considerations, construction considerations, and design details and specifications are presented. Finally, two example problems are presented to demonstrate design calculations for bioretention in areas with poor draining soils/elevated water tables and areas with well draining soils/deep water tables.

### 1.1 Design Features of Typical System

Bioretention systems can be designed similarly to traditional retention systems, where they store and infiltrate water, or as a detention system, where they contain an underdrain to collect water that has been filtered through system aggregate layers including an optional BAM layer. If added, the BAM layer can provide extra nutrient removal, but it is not required. However, a few distinguishable features include being smaller scale, the use of high permeability layers to increase water storage, and the use of vegetation, specifically including flowering vegetation. It should be noted that this is not intended to be a linear practice. Bioretention discussed in this manual has two primary designs discussed above, namely one without an underdrain and one with an underdrain. Bioretention without an underdrain is typically used in applications where the system has 3 feet or more of separation between the bottom of the basin and the SHGWT. These systems typically contain the following layers as a minimum, from system bottom to top:

- 2 inches (minimum) of #89 stone directly on subbase (this optional layer can add to the water storage of the system),
- 6 inches (minimum) of #57 stone (this optional layer can add to the water storage of the system),
- 2 inches (minimum) of #89 stone (this optional layer can add to the water storage of the system),
- 2 inches (minimum) of coarse sand (this optional layer can add to the water storage of the system),
- 1 foot (minimum) of BAM (this optional layer can be added to protect sensitive groundwater conditions),
- 6 inches (minimum) of growth media, and
- 3 inches (minimum) of mulch.

The above are examples of stone gradations that can be used. However, other stone gradations can also be used, but they need to be selected such that the pore sizes of the base material are not sufficiently large to allow the top layer to fill in voids. Some mixing at interface, interstitial mixing, is expected but a subsequent layer should be able to be built up. This bridging should eliminate need for filter fabrics since they are prone to clogging. Many nutrient removal practices encourage

growth of biofilm for the uptake/removal mechanism. While performing an inherent beneficial process, if excess biofilm concentrates along a filter fabric, it will choke out the pores resulting in a significant reduction in permeability and potentially clogging the fabric. It is noted that a geotextile filter fabric could be beneficial if installed on the sides of the bioretention system to minimize mixing with parent soils. It is noted that no filter fabric should be installed on the interface of the infiltration area.

Bioretention systems should be depressed areas with a maximum ponding depth of approximately 1 foot and a freeboard of approximately 1 foot. The maximum slope from the top of bank to the bioretention bottom is to be 4:1 (H:V) if fenced and 5:1 if unfenced. The points of inflow and outflow should leverage hard or soft armoring techniques to protect against erosion. Florida native plants appropriate for the expected conditions, i.e., water depth/duration, amount of light, etc. are to be planted in the bioretention system. Refer to **Appendix A** of the accompanying Volume 1 of this LID manual for plant lists appropriate for the different conditions found within the County as well as guidance on choosing trees based on soil volume available.

For a bioretention system that does not have 3 feet of separation between the bottom of the basin and the SHGWT, or has poor infiltrating soils, an underdrain is required to provide recovery for the system. These systems typically have the following layers as a minimum, from system bottom to top:

- 8 inches (minimum) of #57 stone,
- 2 inches (minimum) of #89 stone,
- 2 inches (minimum) of coarse,
- 1 foot (minimum) of BAM,
- 6 inches (minimum) of growth media, and
- 3 inches (minimum) of mulch.

These are examples of stone gradations that can be used, however, other stone gradations can also be used. It is noted that should other stone gradations be used, they need to be selected such that the pore sizes of the base are not sufficiently large to allow the top layer to fill in voids. Some mixing at the interface is normal but a subsequent layer should be able to be built up. The intent of the different stone bridging layers is to eliminate the need for filter fabrics, since they are prone to clogging. This is due to the fact that this practice/media encourages the growth of biofilm, which while enhances nutrient removals, it can choke out pores if it concentrates along filter fabric interface.

A geotextile filter fabric should be installed on the sides and bottom of the bioretention system to minimize mixing with parent soils. An underdrain, minimum 6 inch diameter perforated pipe, should be installed to collect water that percolates through the system and direct the collected water to the existing drainage system. Additionally, an overflow pipe (minimum 6 inch diameter) and cleanout port (minimum 6 inch diameter) should be installed to ensure proper overflow and that the system can be maintained.

Bioretention systems should accommodate a maximum ponding depth of approximately 1 foot and freeboard depth of approximately 1 foot. The maximum slope from the top of bank to the bioretention bottom should be 4:1 (H:V) if fenced and 5:1 if unfenced. The points of inflow should leverage hard or soft armoring techniques to protect against erosion. Florida native plants appropriate for the expected conditions, i.e., water depth/duration, amount of light, etc. are to be planted in the bioretention system. Refer to **Appendix A** of the accompanying Volume 1 of this LID manual for plant lists appropriate for the different conditions found within the County as well as guidance on choosing trees based on the soil volume available.

## 1.2 Design Guidance and Criteria

Bioretention systems are typically used to help reduce the volume of runoff leaving a site and provide filtration and sorption of pollutants by the plants and different media layers. While these systems can alleviate flooding, they will often by themselves not have the capacity to provide the entirety of site flood storage requirements. While these systems are typically incorporated into a design to meet a water quality criteria, the volume provided can be used to off-set flood control volume requirements. Based on this, sizing of these systems will typically be based on the required water quality treatment that must be provided. This sets forth a presumptive criteria that water quality targets are being met if this level treatment is provided. The design example presented below demonstrates the calculation methodology necessary to determine the appropriate water quality treatment volume.

Bioretention systems are composed of specific materials that each serve a specific function within the system. Rock aggregate layers provide water storage, facilitate drainage, provide bridging layers to minimize movement of different materials to different layers, and evenly distribute water. The coarse sand layer performs similar functions as the rock aggregate layers, providing some water storage, bridging, and facilitating drainage. The mulch layer is intended to hold moisture in the system and minimize weed growth. The water storage associated with these layers can be determined by multiplying the material depth by the area and the porosity (**Table 1-1**).

**Table 1-1. Porosity of Materials used in Bioretention Areas**

Material	Recommended Porosity Value	Reference
#89 Stone	25%	BMPTrains, 2020, v4.3.2
#57 Stone	21%	BMPTrains, 2020, v4.3.2
Coarse Sand	18%	Woessner & Poeter, 2020
BAM	20%	BMPTrains, 2020, v4.3.2
Mulch	70%	Sustainable Technologies, 2022
Growth Media (Sandy Loam)	14%	Minnesota Stormwater Manual, 2022

The ponding volume on top of the mulch layer can be determined using the equation below:

$$(A_1 \times D) + \left( (A_2 - A_1) \times D \times \frac{1}{2} \right) = V$$

Where:

$A_1$  = Area of the bottom slice of the ponding depth (ft<sup>2</sup>)

$A_2$  = Area of the top slice of the ponding depth (ft<sup>2</sup>)

D = Ponding depth (ft)

V = Volume of the ponding area (ft<sup>3</sup>)

Florida Friendly Landscaping should be leveraged and appropriate plants chosen based on the expected conditions. Additionally, consideration for the mature plant size should be considered when selecting plants. If the practice used is not going to provide sufficient root zone and soil volume needed for the mature plant, it is recommended to use something smaller and more appropriate. Along those lines, due to the scale of typical bioretention systems, many tree species will not be appropriate for these systems. The plant lists supplied in **Appendix A** of the accompanying Volume 1 of this LID manual should be referred for guidance on plant selection as well as guidance on choosing trees based on soil volume available.

Finally, some additional considerations are related to how water enters or leaves these systems. Inflow points should be protected using either a hard or soft armoring approach, depending on the anticipated flow rates and velocities. The State of Florida Erosion and Sediment Control Designer and Reviewer Manual (July 2013) provides guidance on acceptable velocities for different armoring practices. Similarly, overflow from the bioretention system should be protected. An

internal piped overflow, minimum of 6 inch diameter, could also be used. Bioretention in areas that incorporate an underdrain into the design must ensure that sufficient underdrains be provided to drain the treatment volume within 72 hours (SFWMD, 2016; SJRWMD, 2018). This can be checked using a modified version of the Manning’s Equation:

$$d_i = \left( \frac{1630 \times Q_p \times n}{\sqrt{S}} \right)^{3/8}$$

Where:

$d_i$  = Inside pipe diameter (in)

$n$  = Manning’s coefficient of roughness

$Q_p$  = Peak discharge rate (cfs)

$S$  = Slope of pipe (ft/ft)

### 1.3 Site Suitability

Bioretention systems should be strategically placed based on site conditions. The natural site topography should be considered and placement be congruent with the natural low spots within the site. It is noted that it is not recommended to install bioretention where slopes are 10% or greater. Additionally, bioretention system design should incorporate an underdrain for systems that have less than 3 feet of separation between the SHGWT and the system bottom. It is recommended to incorporate a media layer in systems with underdrains, in sensitive groundwater areas, or in special basins to provide additional nutrient removal.

Additionally, the built-out conditions must be considered. For example, a system using trees should be sited at a minimum of 10 feet away from structures or sensitive road base systems to prevent damage to structures due to seepage or flooding. The site should also account for the necessary soil volume and root space needed for the planned vegetation. If the soil volume is appropriate, the area shall be planted with trees with a 3 inch or less diameter with shrubs and/or grasses.

It is good engineering practice to consider other infrastructure that could be impacted by the proposed bioretention system such as road bases and/or building foundations. To address this, incorporation of an impermeable layer and/or root barrier can be used to mitigate the risk of damage due to water and/or plant roots. However, this practice is not applicable for specific species, such as *Quercus spp*, commonly known as oak trees. It should be noted that even with the use of a root barrier, the “right plant, right place” practice should be prioritized over the dependence on a root barrier to prevent underground damage. For example, it is possible for roots to grow both over and under this barrier. Additionally, nearby wastewater treatment practices should be considered and infiltrating practices, such as bioretention, should not be placed over a septic drainfield and must be at least 75 feet away from public or private potable wells.



As bioretention systems are vegetation based practices, it is important to consider sun requirements as well as moisture conditions. The vegetation guidance provided in **Appendix A** of the accompanying Volume 1 of this LID manual should be referenced for guidance on plant selection as well as guidance on choosing trees based on soil volume available.

## 1.4 Pollutant Removal Efficiencies

The pollutant removal efficiency for bioretention systems is based on the removal mechanisms of this practice. In areas where stormwater can be infiltrated and are not within sensitive groundwater areas, it is assumed that the pollutants associated with the water that infiltrates into the ground are removed. If the area has sensitive groundwater conditions and loadings to the groundwater is of interest, such as the Wekiwa Springs PFA, a BAM layer is recommended to provide treatment of water as it infiltrates into the ground and the removal efficiency relies on the characteristics of the BAM layer. To determine the water quality benefit, estimate the average annual volume of water infiltrated into the ground, multiply by the appropriate event mean concentration (EMC), and then multiply by the removal efficiency of the pollution control media used. The average annual volume of water infiltrated can be estimated by leveraging continuous simulation modeling or the methods of Harper and Baker (2007). Additionally, there are models and calculation tools that are based on the Harper and Baker (2007) method, such as the BMP Trains model, which can be used to estimate the water quality benefit of implementing bioretention systems.

## 1.5 Regulatory and Permitting Considerations

Applicable criteria for the governing water management district are to be applied on a site by site basis. It is anticipated that bioretention projects will require an Environmental Resource Permit (ERP) from the corresponding water management district (SFWMD, 2016; SJRWMD, 2018). For a project to qualify for an ERP it must be demonstrated that the proposed project will not result in upstream flooding or increases in peak stage, or not result in increases in peak discharge rates from the site, as well as meet water quality treatment requirements. It is noted that stormwater treatment performance standards vary depending on a number of site factors and are summarized as follows:

- If the proposed system discharges directly/indirectly to surface waters, it falls under the MS4 and NPDES rules,
- If the proposed system discharges directly to an Outstanding Florida Waterbody (OFW) or Outstanding Florida Springs (OFS), it falls under the FDEP OFW and OFS rule,
- If the proposed system is within waterbodies with TMDLs, it falls under the EPA rule which delegates the enforcing authority to FDEP, and
- If the proposed system is within watersheds that are on the verified impaired waterbodies list, sensitive groundwater areas, or waterbodies with BMAPS, 4b, or 4e plans, it falls under the FDEP rule.

The specific water quality treatment volume required varies depending on the criteria listed above. Additionally, for basins that do not currently require that additional 50% treatment volume, this

manual requires the criteria be provided in all basins in Orange County, in addition to the relevant water management district requirements. This requirement may be affected by the pending statewide stormwater rule and should be evaluated after adoption of the rule, as this manual was started prior to the adoption of the statewide stormwater rule.

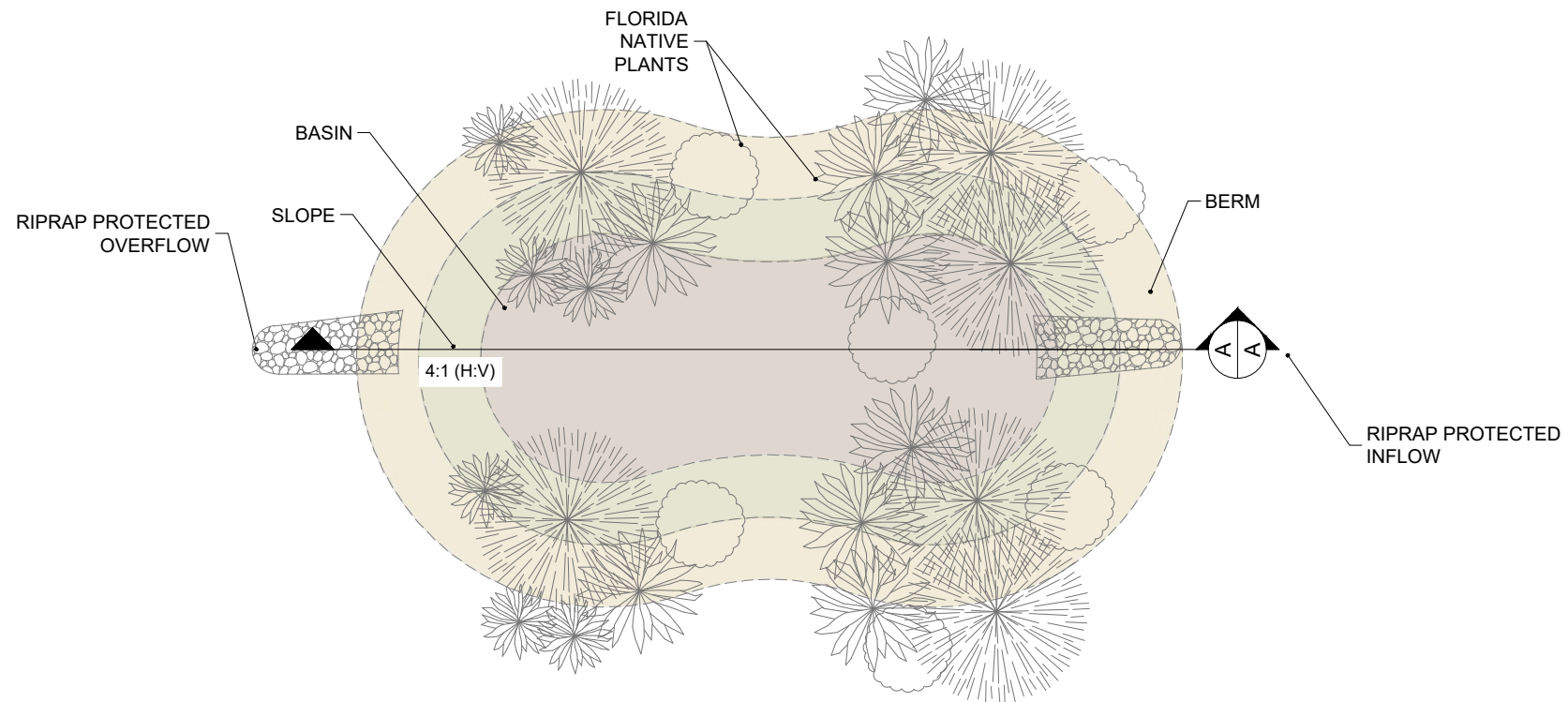
## 1.6 Construction Considerations

The following construction considerations should be considered when building a bioretention system:

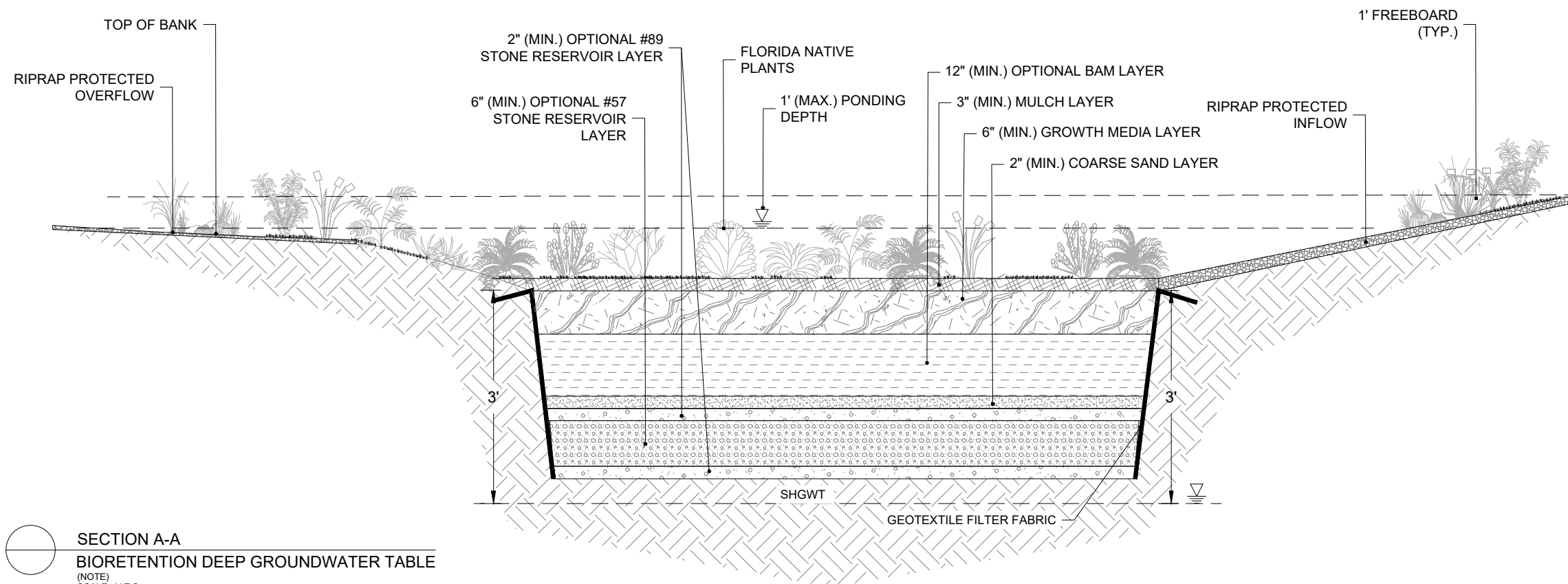
- Utilities should be contacted prior to digging to ensure it is clear to dig, otherwise relocation of the utilities will be necessary. The area to be excavated should be determined based on calculations done to meet nutrient removal needs.
  - No utility or other infrastructure shall be placed in the location of the LID structure that would interfere with the function or maintenance of the structure.
- Existing low areas should be considered for bioretention systems since minimal grading will be needed.
- Every effort should be made to minimize compaction of soils where the bioretention system is proposed.
- Vegetation should be planted densely to limit exposed soils and mulch applied in areas around plants to protect soils and hold moisture.
- A sufficient staging area should be provided where:
  - Plants can get sufficient sunlight and be easily watered to keep them alive prior to planting, and
  - Growth media, pollution control media, and rock aggregates can be stored without risk of contamination or mixing with site soils.
- Appropriate erosion and sediment control practices be incorporated to minimize site erosion and sediment loss.
- Typically, trees are located at the top of the bank or slope. Shrubs, grasses, and groundcover are planted on the slope. Groundcover, perennials, sedges, rushes, and forbs are planted at the bottom and lower sides that may be inundated briefly.
  - Typical plants may include cypress, magnolia, and oaks with iris and grasses in larger projects or persimmon, chokecherry, and dwarf fakahatchee grass in smaller projects. The full list of vegetation can be found in **Appendix A** of the accompanying Volume 1 of this LID manual should be referenced for guidance on plant selection as well as guidance on choosing trees based on soil volume available.

## 1.7 Design Details and Specifications

As part of this effort, design details and general specifications were developed. **Figure 1-1** and **Figure 1-2** show the relevant design details for bioretention systems both without and with an underdrain. General specifications are also included on each detail.



PLAN  
 BIORETENTION DEEP GROUNDWATER TABLE  
 (NOTE)  
 SCALE: N.T.S.



SECTION A-A  
 BIORETENTION DEEP GROUNDWATER TABLE  
 (NOTE)  
 SCALE: N.T.S.

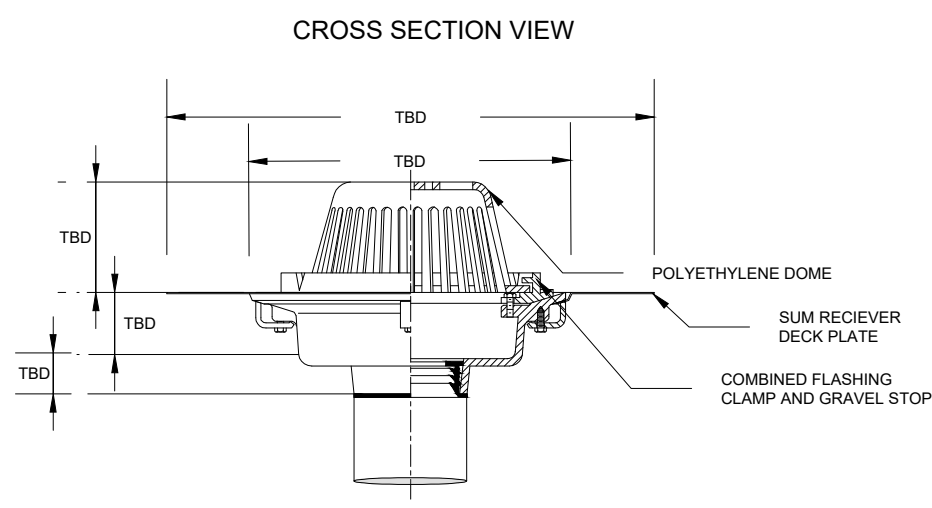
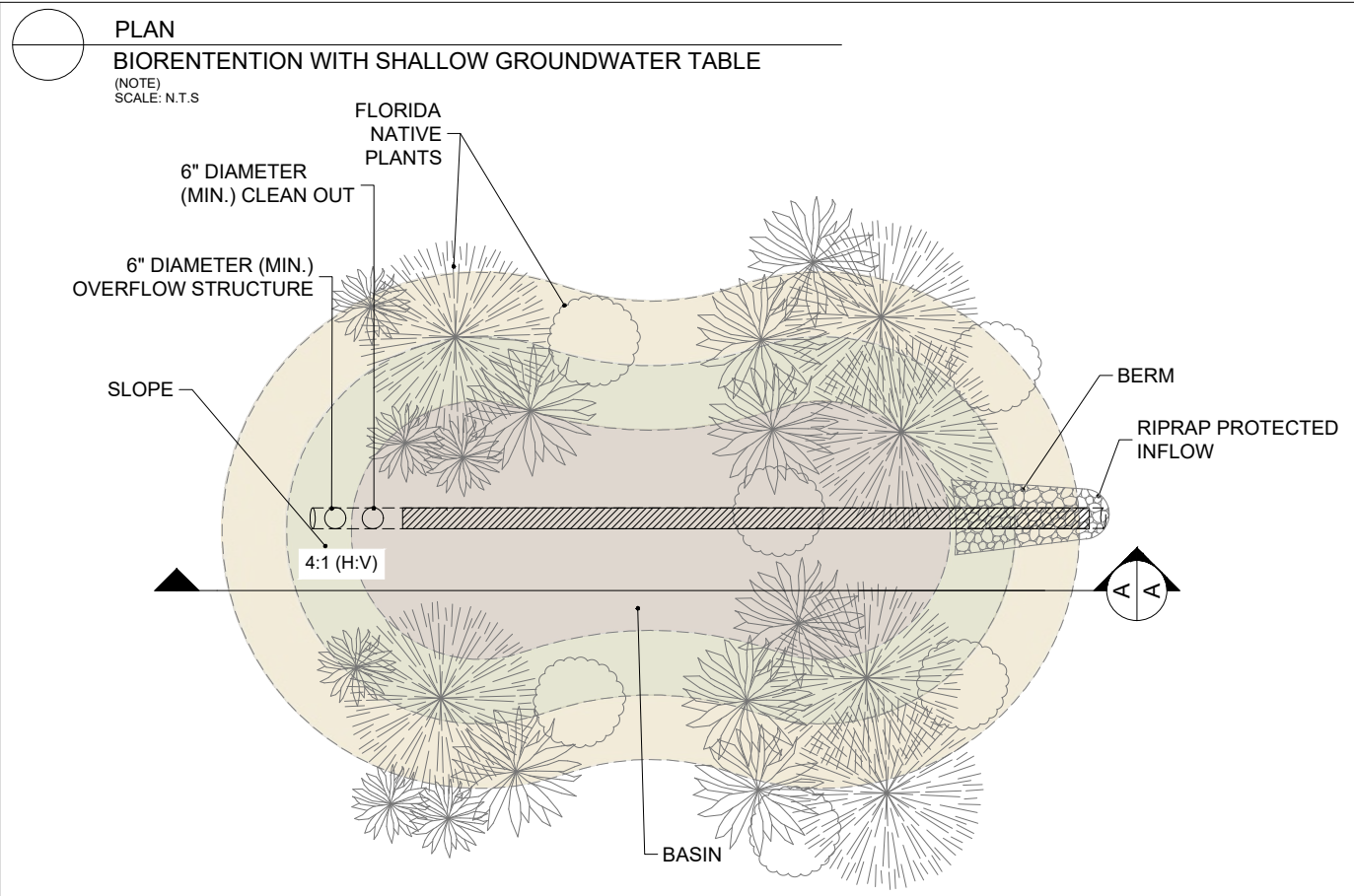
NOTES:

1. CONTACT UTILITY COMPANY AND ENSURE UTILITY LINES ARE PROPERLY LOCATED PRIOR TO DIGGING OR TRENCHING.
2. FOR EXISTING TREES, CONSULT A PROFESSIONAL ARBORIST IF ROOT TRIMMING IS REQUIRED.
3. THE MULCH LAYER IS INTENDED TO MINIMIZE EROSION, MINIMIZE WEEDS, AND HOLD MOISTURE IN THE SYSTEM. THE MULCH SHOULD CONSIST OF LARGE CHIP HARDWOOD MULCH (CYPRESS MULCH IS NOT RECOMMENDED).
4. THE GROWTH MEDIA IS INTENDED TO PROMOTE INFILTRATION AS WELL AS HEALTHY PLANT GROWTH. GROWTH MEDIA SHALL BE A MINIMUM OF 6 INCHES IN DEPTH AND SHALL BE COMPOSED OF 50% COARSE SAND (ASTM C-33), 25% TOPSOIL (LESS THAN 5% FINES PASSING #200 SIEVE), AND ORGANIC COMPOST (LEAF AND MULCH MIX). MEDIA SHALL ACHIEVE INFILTRATION RATES THAT EXCEEDS 2 INCHES PER HOUR.
5. THE COARSE SAND LAYER IS INTENDED TO ACT AS A SUPPORT LAYER FOR THE BAM AND PROVIDE A BRIDGING LAYER TO PREVENT THE MIGRATION OF BAM MEDIA FROM ENTERING THE OPTIONAL STONE RESERVOIR LAYERS BELOW. THE COARSE SAND SHOULD BE WASHED AND CONSISTENT WITH ASTM C-33. SAND SHALL BE FREE FROM OBJECTIONAL WEEDS, LITTER, SODS, STIFF CLAY, STONES, ROOTS, TRASH, HERBICIDES, TOXIC SUBSTANCES, OR ANY OTHER CHEMICAL THAT MAY BE HARMFUL TO THE ENVIRONMENT.
6. THE OPTIONAL #89 STONE LAYER IS INTENDED TO ACT AS A BRIDGING LAYER AND INCREASE WATER STORAGE WITHIN THE SYSTEM. THE AGGREGATE SIZING SHOULD BE CONSISTENT WITH AASHTO M 43, WITH A NOMINAL DIAMETER OF 3/8 OF AN INCH. ALL AGGREGATE STONE IS TO BE WASHED TO MINIMIZE THE INTRODUCTION OF FINES INTO THE SYSTEM.
7. THE OPTIONAL #57 STONE LAYER IS INTENDED TO ACT AS A STORAGE RESERVOIR TO INCREASE THE WATER STORAGE OF THE SYSTEM. THE AGGREGATE SIZING SHOULD BE CONSISTENT WITH AASHTO M43, WITH A NOMINAL DIAMETER OF 1.5 INCHES. ALL AGGREGATE STONE IS TO BE WASHED TO MINIMIZE THE INTRODUCTION OF FINES INTO THE SYSTEM.
8. THE OPTIONAL BAM LAYER IS INTENDED TO PROVIDE TREATMENT OF WATER AS IT INFILTRATES INTO THE GROUND. THIS OPTIONAL LAYER IS INTENDED TO BE USED IN AREAS OF SENSITIVE GROUNDWATER, SUCH AS WITHIN THE WEKIWA SPRINGS SPRINGSHED.
9. IT IS RECOMMENDED TO INCORPORATE EITHER A SOFT OR HARD ARMORING INFLOW/OUTFLOW POINT TO MINIMIZE EROSION TO THE BIORETENTION. THIS CAN BE USING RIPRAP OR OTHER METHODS AS APPROPRIATE BASED ON THE FLOW CONDITIONS EXPECTED.

BIORETENTION WITH DEEP  
 GROUNDWATER TABLE  
 LID MANUAL DETAILS  
 ORANGE COUNTY; FLORIDA

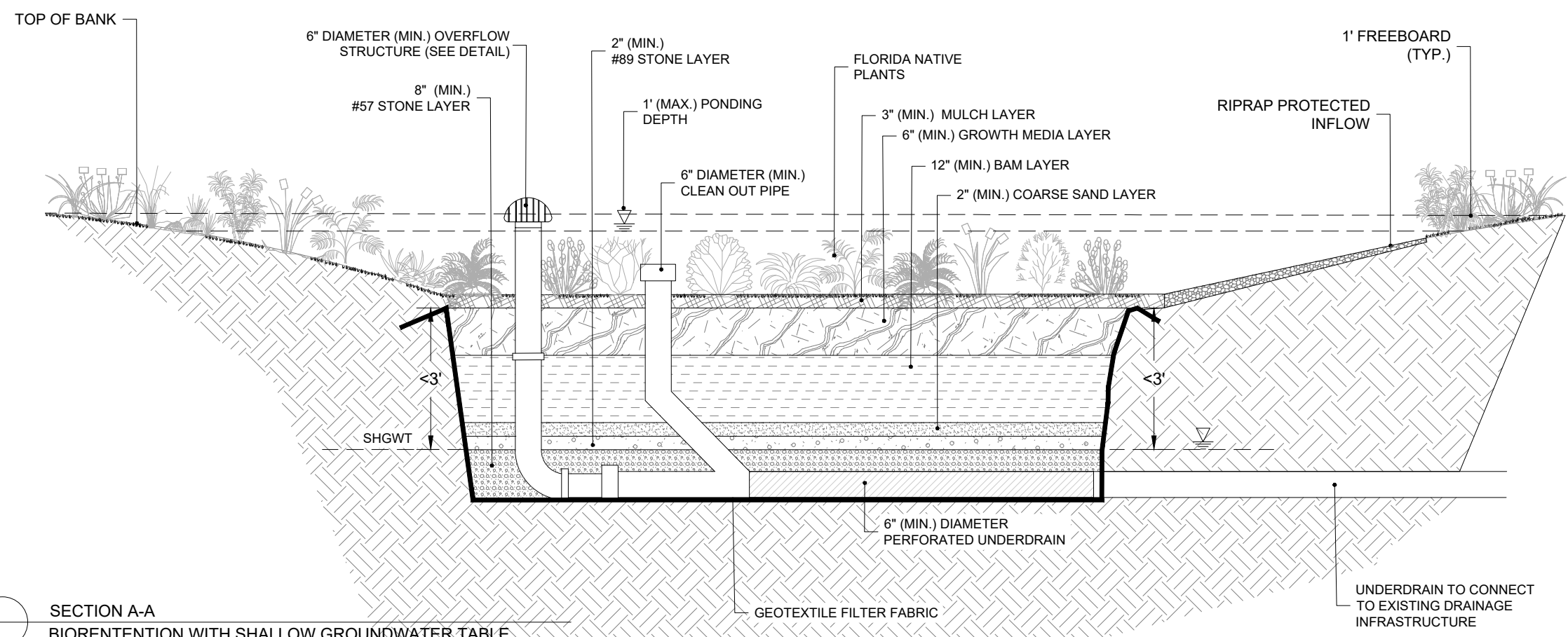


FIGURE  
 1-1



**OVERFLOW STRUCTURE - DEBRIS CAGE**

- NOTES:**
- CONTACT UTILITY COMPANY AND ENSURE UTILITY LINES ARE PROPERLY LOCATED PRIOR TO DIGGING OR TRENCHING.
  - FOR EXISTING TREES, CONSULT A PROFESSIONAL ARBORIST IF ROOT TRIMMING IS REQUIRED.
  - THE MULCH LAYER IS INTENDED TO MINIMIZE EROSION, MINIMIZE WEEDS, AND HOLD MOISTURE IN THE SYSTEM. THE MULCH SHOULD CONSIST OF LARGE CHIP HARDWOOD MULCH (CYPRESS MULCH IS NOT RECOMMENDED).
  - THE GROWTH MEDIA IS INTENDED TO PROMOTE INFILTRATION AS WELL AS HEALTHY PLANT GROWTH. GROWTH MEDIA SHALL BE A MINIMUM OF 6 INCHES IN DEPTH AND SHALL BE COMPOSED OF 50% COARSE SAND (ASTM C-33), 25% TOPSOIL (LESS THAN 5% FINES PASSING #200 SIEVE), AND ORGANIC COMPOST (LEAF AND MULCH MIX). MEDIA SHALL ACHIEVE INFILTRATION RATES THAT EXCEEDS 2 INCHES PER HOUR.
  - THE BAM LAYER IS INTENDED TO PROVIDE TN AND TP REMOVAL FROM STORMWATER BEFORE IT IS COLLECTED BY THE UNDERDRAIN PIPE. BAM IS A GENERIC TERM FOR ANY MEDIA THAT LEVERAGES BIOLOGICAL, CHEMICAL, AND/OR PHYSICAL PROCESSES FOR POLLUTANT REMOVAL. MEDIA SHALL ACHIEVE INFILTRATION RATES THAT EXCEEDS 2 INCHES PER HOUR.
  - THE COARSE SAND LAYER IS INTENDED TO ACT AS A SUPPORT LAYER FOR THE BAM AND PROVIDE A BRIDGING LAYER TO PREVENT THE MIGRATION OF BAM MEDIA FROM ENTERING THE STONE RESERVOIR LAYERS BELOW. THE COARSE SAND SHOULD BE WASHED AND CONSISTENT WITH ASTM C-33. SAND SHALL BE FREE FROM OBJECTIONAL WEEDS, LITTER, SODS, STIFF CLAY, STONES, ROOTS, TRASH, HERBICIDES, TOXIC SUBSTANCES, OR ANY OTHER CHEMICAL THAT MAY BE HARMFUL TO THE ENVIRONMENT.
  - THE #89 STONE LAYER IS INTENDED TO ACT AS A BRIDGING LAYER AND INCREASE WATER STORAGE WITHIN THE SYSTEM. THE AGGREGATE SIZING SHOULD BE CONSISTENT WITH AASHTO M 43, WITH A NOMINAL DIAMETER OF 3/8 OF AN INCH. ALL AGGREGATE STONE IS TO BE WASHED TO MINIMIZE THE INTRODUCTION OF FINES INTO THE SYSTEM.
  - THE #57 STONE LAYER IS INTENDED TO ACT AS A DRAINAGE LAYER TO FACILITATE WATER COLLECTION BY THE UNDERDRAIN WHILE ALSO INCREASING THE WATER STORAGE OF THE SYSTEM. THE AGGREGATE SIZING SHOULD BE CONSISTENT WITH AASHTO M43, WITH A NOMINAL DIAMETER OF 1.5 INCHES. ALL AGGREGATE STONE IS TO BE WASHED TO MINIMIZE THE INTRODUCTION OF FINES INTO THE SYSTEM.
  - THE CLEAN OUT PIPE IS INTENDED TO PROVIDE MAINTENANCE ACCESS TO UNBLOCK THE UNDERDRAIN PIPE SHOULD IT BECOME CLOGGED. THE MINIMUM PIPE DIAMETER CONSIDERED SHOULD BE 6 INCHES. THE CLEAN OUT SHOULD BE INSTALLED LEVEL WITH THE FINISHED GRADE AND INCLUDE A THREADED CAP TO PREVENT WATER FROM LEAKING INTO THE PIPE.
  - THE OVERFLOW STRUCTURE IS INTENDED TO PROVIDE DRAINAGE OF EXCESS WATER PAST THE DESIGN VOLUME. IT IS TO BE INSTALLED WITH A SLOTTED DOME OVERFLOW TO PREVENT TRASH AND DEBRIS FROM ENTERING THE UNDERDRAIN. THE SUM OF THE SLOT OPENING SIZES IN THE SLOTTED DOME OVERFLOW MUST BE GREATER THAN THE AREA OF THE OPEN PIPE. THE MINIMUM PIPE DIAMETER CONSIDERED SHOULD BE 6 INCHES.
  - THE PVC UNDERDRAIN PIPE IS TO CONSIST OF A SLOTTED OR PERFORATED PIPE WRAPPED IN A NON-WOVEN FILTER FABRIC AND BE INSTALLED CONSISTENT WITH FDOT STANDARD PLANS INDEX 440-001.
  - IT IS RECOMMENDED TO INCORPORATE EITHER A SOFT OR HARD ARMORING INFLOW POINT TO MINIMIZE EROSION TO THE BIORENTENTION. THIS CAN BE USING RIPRAP OR OTHER METHODS AS APPROPRIATE BASED ON THE FLOW CONDITIONS EXPECTED.
  - A TRASH GUARD IS TO BE INSTALLED SIMILAR TO THE ONE SHOWN IN THE DRAWING TO PREVENT TRASH AND OTHER LARGER DEBRIS FROM GETTING IN.



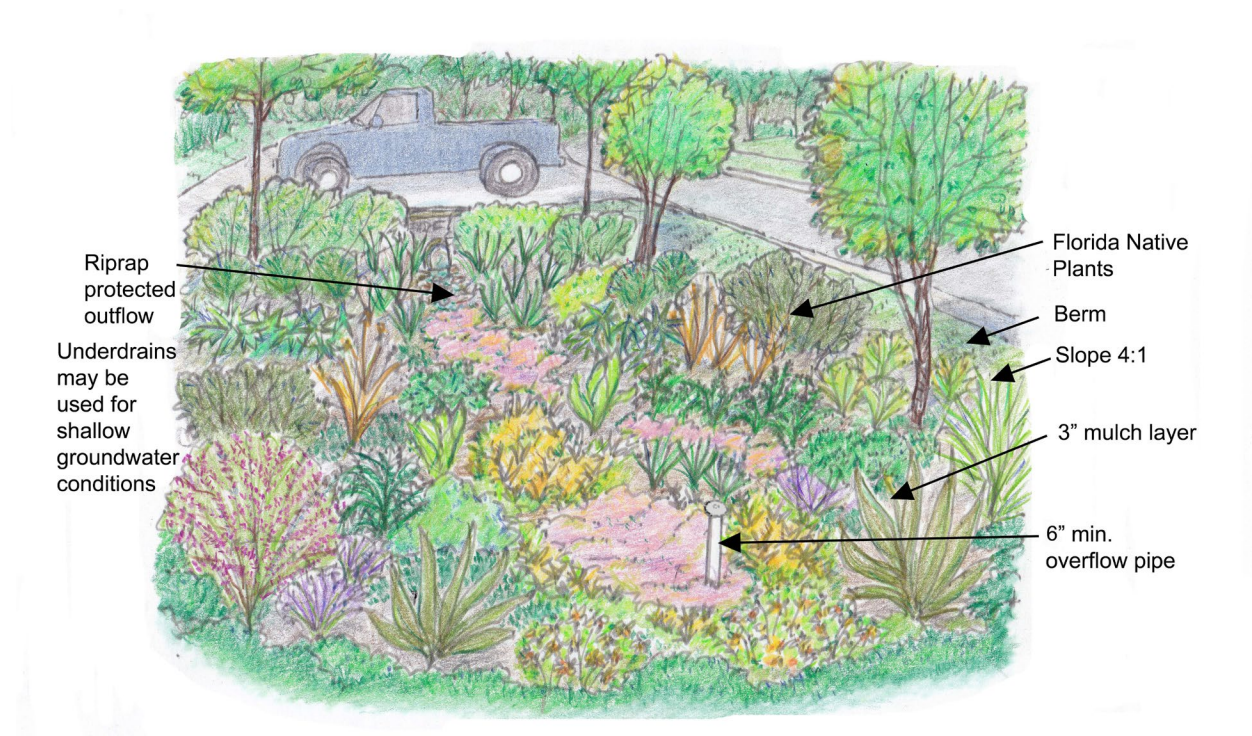
**BIORENTENTION WITH SHALLOW GROUNDWATER TABLE**  
**LID MANUAL DETAILS**  
**ORANGE COUNTY; FLORIDA**

**Geosyntec** consultants 

**FIGURE 1-2**

## 1.8 Artist Renderings

Presented below is an artist rendering of how this practice may look incorporated into the urban landscape (Figure 1-3).



**Figure 1-3: Bioretention System in an Urban Landscape Setting (Alliance Design & Construction, Inc.)**

## 1.9 Inspection, Maintenance, and Monitoring

Operation of bioretention systems requires adequate maintenance to ensure proper function. This includes frequent inspections to identify maintenance issues, performance monitoring, and general weeding/debris removal. This attachment provides detailed information on the operation and maintenance required to ensure proper function of bioretention systems. This attachment also includes an inspection and maintenance checklist that goes over site conditions, various inspection items, and allows maintenance personnel to note if maintenance is needed and what corrective actions are recommended (**Appendix 1A** and **1D**). A flow chart is included to be used in tandem with the checklist, as it provides step by step action items to guide the maintenance personnel through the task (**Appendix 1B** and **1E**). The numbered items on the flow chart correspond to the numbered items in the checklist. Additionally, optional monitoring guidance is provided in **Appendix 1C** and **1F**.

The maintenance personnel are required to take a minimum of five photographs as well as notes describing the conditions of the bioretention area. It is noted that five baseline photos should be taken of the bioretention system after construction is complete. Guidance on where the photos

should be taken can be found at the end of **Appendix 1A** and **1D**. The notes should elaborate on any of the topics listed in the checklist but can also cover other observations made or actions taken that the maintenance personnel deems important. The maintenance checklists are required to be submitted annually to the County at an agreed upon date to ensure that the bioretention system is being regularly maintained. Every 5 years, a professional engineer must check the system to ensure that it is functioning as designed and sign off on its performance. An alternative maintenance plan and/or schedule may be used with approval from the County engineer.

### 1.9.1 Inspection Steps and Checklists for Bioretention Systems without Underdrains

This section provides steps, a checklist, and a flow chart for maintenance personnel to use while inspecting bioretention systems without underdrains. The checklist can be found in **Appendix 1A** and the flow chart can be found in **Appendix 1B**. A plan sheet for each site is to be included with every inspection sheet and it is encouraged that the maintenance personnel mark up the plan sheet as needed. Inspection includes the system surface, vegetation, and overall system performance. To aid the inspector during the maintenance process and in completing the checklist, the necessary inspection and maintenance activities are described below.

#### 1.9.1.1 Bioretention System Surface Activities

Inspection of system surface activities includes inspecting the bioretention system for evidence of erosion, determining if the mulch layer is in place, and if the inflow and overflow points are free of debris. The below descriptions are intended to provide more detailed information on the specific action items for bioretention surface inspection noted in the check list.

- BS1:** Bioretention systems should have all their surface areas inspected monthly for evidence of erosion. If there is evidence of erosion, such as rills or gullies or accumulation of sediments, the impacted areas should be restored and incorporation of erosion and sediment control products to protect against erosive forces should be considered. This can include stabilization practices such as rolled erosion control products, hard armoring, riprap, or the incorporation of additional vegetation to protect soils and slow the velocity of the incoming water.
- BS2:** Bioretention systems mulch layer should be inspected monthly to determine if the mulch layer is still in place. If mulch has washed away, more mulch needs to be added until the desired depth (3 inches) is achieved. Mulch should be applied and raked to ensure even coverage. It is noted that mulch should be replaced in late winter before new growth sprouts. If mulch continues to get washed out, this could be indicative of a design issue that is failing to dissipate the velocity of water entering the system. Should this happen, it is recommended to examine how the system performs during a rainfall event to see how water is entering the system and where some additional stabilization practices should be implemented to slow the velocity of the incoming water.
- BS3:** Bioretention systems inflow and overflow points should be inspected monthly to determine if the inflow and overflow points are in working order. The inflow should be protected by riprap. The presence of riprap protects the inflow area from eroding by slowing the velocity of the incoming water. If the riprap is out of place or has debris in it,

it should be replaced as designed and debris should be removed to ensure proper flow of incoming water.

### **1.9.1.2 Vegetation Management**

Inspection of vegetation management activities include inspecting the bioretention system for evidence of dead and/or unhealthy plants, that the plant community is still according to approved plans, and that the vegetation has a manicured look. The below descriptions are intended to provide more detailed information on the specific action items for bioretention vegetation management noted in the check list.

- VM1:** The vegetation in the bioretention system should be inspected monthly for dead and/or unhealthy plants. If present, the affected plants should be removed and replaced. If a particular plant type appears to not do well in a particular location, e.g., multiple plant replacements at a particular location, observations should be made to attempt to determine the reason for failure. Examples could be too much/not enough sunlight, too much/not enough water, or excessive erosive forces. If the plant is doing well in other areas of the bioretention system, observations of those locations should be made to see what is different from the problem location. New plant types from the appropriate plant lists included in this manual should be tried in the problem location until a successful variety is identified. The plants should also be inspected for evidence of pest infestations. Pest infestations should be treated using species specific natural control methods when possible, and chemical controls should be avoided.
- VM2:** The vegetation in the bioretention system should be inspected monthly to ensure that the plant community composition is still according to approved plans. As-built plans that include relevant design details should be provided to the maintenance crew. Additionally, a list of the plants in the bioretention system should be provided, including pictures of the plant at all stages of life (seedlings, juvenile, mature, dormant (if applicable)), as well as examples of healthy and not conditions. Signs of unacceptable water quality indicates that the system is not functioning as designed, along with unplanned growth of aquatic/wetland plants in the bioretention area. Plants that are not part of the intended plant list, such as weeds, invasive exotic plants, and nuisance species, are to be removed. Weeding should be done by hand, not with a power trimmer, and the plant should be pulled from the base of the plant, making sure to remove as much of the root ball as possible. New plants should be installed according to the original plant list if sufficient vegetative cover is not achieved.
- VM3:** The vegetation in the bioretention system should be inspected monthly to determine if the vegetation present has a manicured look, i.e., does it need to be pruned. Maintenance personnel are to prune, edge, weed, mow, irrigate, and fertilize plants as needed to maintain a well-manicured look. Fertilization should be minimized to the extent practical and done according to State and County rules when necessary. These practices are most frequently needed during the establishment period. Some grasses need cutting back during winter. Plants should be trimmed back if they are impeding flow or walking pathways.

### 1.9.1.3 System Performance

Inspection of the bioretention system surface activities include inspecting the bioretention system for evidence of standing water, debris, and/or sediment accumulation that may impact the performance of the bioretention system. The below descriptions are intended to provide more detailed information on the specific action items for bioretention system performance noted in the check list.

- SP1:** The bioretention system should be inspected monthly for evidence of standing water. Presence of wetland species can also be used as an indicator of extended ponding and saturated soils. If there is standing water, it is likely that one of the system layers are not functioning properly or are clogged. This can be due to several factors including accumulation of excess debris that can clog the system, compaction of the media layers, or long-term accumulation of fines along the growth media and mulch interface. Initial steps to address this issue should include removal of accumulated debris and sediments. Additionally, scarifying the growth media surface can increase infiltration capacity. If these steps fail to remedy the problem, some of the layers may need to be replaced to restore full function. It is recommended to try and identify which layer needs replacing rather than replacing the entire system. To do this, perform double ring infiltrometer testing at each layer by digging down to the interface of each layer and performing a test. Prevention of future accumulation of debris and sediments may necessitate pretreatment.
- SP2:** The bioretention system should be inspected monthly for evidence of debris and sediment accumulation. Debris and sediment accumulation should be removed using manual methods. Prevention of future accumulation of debris and sediments may necessitate pretreatment to prevent frequent clogging of media.

### 1.9.2 Water Quality Performance Monitoring Guidance for Bioretention Systems without Underdrains

Understanding the true performance of bioretention systems will require adequate monitoring to ensure proper characterization of the practice. Optional water quality monitoring guidance can be found in **Appendix 1C**.

### 1.9.3 Inspection Steps and Checklists for Bioretention Systems with Underdrains

Operation of bioretention systems requires adequate maintenance to ensure proper function. This includes frequent inspections to identify maintenance issues, performance monitoring, and general weeding/debris removal.

This section provides steps, a checklist, and a flow chart for maintenance personnel to use while inspecting bioretention systems. The checklist can be found in **Appendix 1D** and the flow chart can be found in **Appendix 1E**. A plan sheet for each site is to be included with every inspection sheet and it is encouraged that the maintenance personnel mark up the plan sheet as needed. Inspection includes the system surface, vegetation, and overall system performance. To aid the inspector during the maintenance process and in completing the checklist, the necessary inspection and maintenance activities are described below.



### **1.9.3.1 Bioretention System Surface Activities**

Inspection of system surface activities includes inspecting the bioretention system for evidence of erosion, determining if the mulch layer is in place, and if the inflow and overflow points are free of debris. The below descriptions are intended to provide more detailed information on the specific action items for bioretention surface inspection noted in the check list.

- BS1:** Bioretention systems should have all their surface areas inspected monthly for evidence of erosion. If there is evidence of erosion, such as rills or gullies or accumulation of sediments, the impacted areas should be restored and incorporation of erosion and sediment control products to protect against erosive forces should be considered. This can include stabilization practices such as rolled erosion control products, hard armoring, riprap, or the incorporation of additional vegetation to protect soils and slow the velocity of the incoming water.
- BS2:** Bioretention systems mulch layer should be inspected monthly to determine if the mulch layer is still in place. If mulch has washed away, more mulch needs to be added until the desired depth (3 inches) is achieved. Mulch should be applied and raked to ensure even coverage. It is noted that mulch should be replaced in late winter before new growth sprouts. If mulch continues to get washed out, this could be indicative of a design issue that is failing to dissipate the velocity of water entering the system. Should this happen, it is recommended to examine how the system performs during a rainfall event to see how water is entering the system and where some additional stabilization practices should be implemented to slow the velocity of the incoming water.
- BS3:** Bioretention systems inflow and overflow points should be inspected monthly to determine if the inflow and overflow points are in working order. The inflow should be protected by riprap. The presence of riprap protects the inflow area from eroding by slowing the velocity of the incoming water. If the riprap is out of place or has debris in it, it should be replaced as designed and debris should be removed to ensure proper flow of incoming water. All underdrain pipes should be flushed and/or vacuumed once a year to ensure proper inflow and outflow of water.

### **1.9.3.2 Vegetation Management**

Inspection of vegetation management activities include inspecting the bioretention system for evidence of dead and/or unhealthy plants, that the plant community is still according to approved plans, and that the vegetation has a manicured look. The below descriptions are intended to provide more detailed information on the specific action items for bioretention vegetation management noted in the check list.

- VM1:** The vegetation in the bioretention system should be inspected monthly for dead and/or unhealthy plants. If present, the affected plants should be removed and replaced. If a particular plant type appears to not do well in a particular location, e.g., multiple plant replacements at a particular location, observations should be made to attempt to determine the reason for failure. Examples could be too much/not enough sunlight, too much/not enough water, or excessive erosive forces. If the plant is doing well in other areas of the

bioretention system, observations of those locations should be made to see what is different from the problem location. New plant types from the appropriate plant lists included in this manual should be tried in the problem location until a successful variety is identified. The plants should also be inspected for evidence of pest infestations. Pest infestations should be treated using species specific natural control methods when possible, and chemical controls should be avoided.

- VM2:** The vegetation in the bioretention system should be inspected monthly to ensure that plant community composition is still according to approved plans. As-built plans that include relevant design details should be provided to the maintenance crew. Additionally, a list of the plants in the bioretention system should be provided, including pictures of the plant at all stages of life (seedlings, juvenile, mature, dormant (if applicable)), as well as examples of healthy and not conditions. Signs of unacceptable water quality indicates that the system is not functioning as designed, along with unplanned growth of aquatic/wetland plants in the bioretention area. Plants that are not part of the intended plant list, such as weeds, invasive exotic plants, and nuisance species, are to be removed. Weeding should be done by hand, not with a power trimmer, and the plant should be pulled from the base of the plant, making sure to remove as much of the root ball as possible. New plants should be installed according to the original plant list if sufficient vegetative cover is not achieved.
- VM3:** The vegetation in the bioretention system should be inspected monthly to determine if the vegetation present has a manicured look, i.e., does it need to be pruned. Maintenance personnel are to prune, edge, weed, mow irrigate, and fertilize plants as needed to maintain a well-manicured look. Fertilization should be minimized to the extent practical and done according to State and County rules when necessary. These practices are most frequently needed during the establishment period. Some grasses need cutting back during winter. Plants should be trimmed back if they are impeding pathways.

### 1.9.3.3 System Performance

Inspection of the bioretention system surface activities include inspecting the bioretention system for evidence of standing water, debris, and/or sediment accumulation that may impact the performance of the bioretention system. The below descriptions are intended to provide more detailed information on the specific action items for bioretention system performance noted in the check list.

- SP1:** The bioretention system should be inspected monthly for evidence of standing water. Presence of wetland species can also be used as an indicator of extended ponding and saturated soils. If there is standing water, it is likely that one of the system layers are not functioning properly or are clogged. This can be due to several factors including accumulation of excess debris that can clog the system, compaction of the media layers, or long-term accumulation of fines along the growth media and mulch interface. Initial steps to address this issue should include removal of accumulated debris and sediments. Additionally, scarifying the growth media surface can increase infiltration capacity. All underdrain pipes in the system should be flushed and/or vacuumed once a year to prevent sediment buildup and clogging. If these steps fail to remedy the problem, some of the layers may need to be replaced to restore full function. It is recommended to try and

identify which layer needs replacing rather than replacing the entire system. To do this, perform double ring infiltrometer testing at each layer by digging down to the interface of each layer and performing a test. Prevention of future accumulation of debris and sediments may necessitate pretreatment.

**SP2:** The bioretention system should be inspected monthly for evidence of debris and sediment accumulation. Debris and sediment accumulation should be removed using manual methods and pipes should be flushed to prevent future accumulation and clogging. Prevention of future accumulation and sediments may necessitate pretreatment to prevent frequency clogging of media.

#### 1.9.4 Water Quality Performance Monitoring Guidance for Bioretention Systems with Underdrains

Understanding the true performance of bioretention systems will require adequate monitoring to ensure proper characterization of the practice. Optional water quality monitoring guidance can be found in **Appendix 1F**.

### 1.10 Design Calculations Example for Well-Draining Sandy Soils

This example calculation examines a scenario with well-draining sandy soils, which would be representative of the western portion of the county where there is a greater occurrence of well-draining sandy soils with deep water tables. For this example, it is assumed that a 3-acre pasture site located within the boundaries of the SJRWMD is to be developed into a high-density commercial site. Soil types are hydrologic soils group (HSG) A. The calculations presented below demonstrate how to design a bioretention system to achieve the required water quality treatment. It is noted that the following example calculation is for projects within special basins, which can be found in FAC 62-330.

The first step is to determine the required treatment volume per the water management district (WMD) and the County criteria. As this practice is an infiltration based practice, the water quality benefit would be associated with the volume of water infiltrated. Since this example scenario is located within the SJRWMD boundary, the SJRWMD criteria for dry retention is the relevant water quality criteria for this project. A summary of pre- and post- development conditions are presented below followed by details of the bioretention design, the required treatment volume, and the final size of the system.

- Site conditions summary
  - Pre-development conditions
    - Land use: 3-acre site, pasture
    - Soil types: HSG A
  - Post-development conditions
    - Land use:
      - 2.4-acre site high density commercial
      - 0.6 acre will be open space (**20% open space requirement**)

- Soil types: HSG A
- Impervious areas:
  - Commercial area will be **60% impervious**
  - 1.8 acres will be impervious
- Proposed LID practice summary
  - Proposed bioretention system is to have the following media layers:
    - 2 inch #89 stone
    - 6 inch #57 stone
    - 2 inch #89 stone
    - 2 inch coarse sand
    - 12 inch BAM (optional)
    - 6 inch growth media
    - 3 inch hard mulch layer
    - Florida Friendly Landscaping
    - 12 inch ponding layer with 4:1 (H:V) side slopes if fenced, 5:1 if unfenced
  - Since groundwater table and soils are not an issue at this site, no underdrain is proposed
- Determination of required treatment volume
  - As previously stated, the proposed system is a dry retention practice. Based on the SJRWMD ERP handbook vol. 2 (SJRWMD, 2018), the water quality treatment volume is either a) 1 inch of runoff or b) 1.25 inches of runoff from the impervious area plus 0.50 inches of runoff from the entire basin; whichever is greater.
    - a):  $\frac{3 \text{ ac} (1 \text{ in})}{12 \text{ in/ft}} = 0.25 \text{ ac} - \text{ft}$
    - b):  $\frac{1.8 \text{ ac} (1.25 \text{ in})}{12 \text{ in/ft}} + \frac{3 \text{ ac} (0.50 \text{ in})}{12 \text{ in/ft}} = 0.3125 \text{ ac} - \text{ft}$
    - Since the 1.25 inch plus 0.5 inches of runoff produces the greater treatment volume, this is the value required by the SJRWMD
  - Per the current state special basin criteria, as listed in FAC 62-330, water quality standard, an additional 50% treatment volume is required. This is calculated as:
    - $0.3125 \text{ ac} - \text{ft} * 1.5 = 0.469 \text{ ac} - \text{ft}$
    - Therefore, the total treatment volume required for this project is 0.469 acre-feet
- Based on the above water quality treatment volume determination, the bioretention system must provide 0.469 acre-feet of storage. Sizing of the bioretention system is an iterative process where an initial area is assumed and based on the standard section of the proposed system, a provided volume can be determined. This is achieved easiest using a spreadsheet so values can be quickly and easily changed until the treatment volume is achieved.
  - Specifically, each aggregate layer is multiplied by the depth, area, and porosity to determine the water volume provided
  - The ponding volume is determined using the methods presented in **Section 1-2**, above

- Following this process, and assuming a rectangular geometry with 4:1 (H:V) slopes for the ponding volume and 1 foot freeboard, a total area at top of bank of 0.31 acres was determined.
- Based on this, a rectangular bioretention system with a 2 inch #89 stone layer, 6 inch #57 stone layer, 2 inch #89 stone layer, 2 inch coarse sand layer, 12 inch BAM layer, 6 inch growth media layer, 3 inch mulch layer, and 1 foot ponding area (with 4:1 side slopes) would need to be 0.31 acres to provide sufficient treatment for a 3 acre high intensity commercial site.
  - It is noted that the example problem sizing of the bioretention system is only for pollutant treatment purposes, not for flood control purposes. However, the bioretention system will provide some flood control, resulting in a smaller pond needed for flood control elsewhere on the site.

### 1.11 Design Calculations Example for Poor-Draining / High Water Table Soils or Sensitive Groundwater Areas

This example calculation examines a scenario with poorly-drained sandy soils, which would be representative of the eastern portion of the county where there is a greater occurrence of poorly-drained sandy soils with shallow water tables. For this example, it is assumed that a 3-acre pasture site located within the boundaries of the SJRWMD is to be developed into a high-density commercial site. Soil types are dual-hydrologic soils group (HSG) A/D. In scenarios where the soil type is a dual-hydrologic group, it is recommended to use the second letter for a more conservative estimate. The calculations presented below demonstrate how to design a bioretention system in high groundwater conditions to achieve the required water quality treatment. It is noted that the following example calculation is for projects within special basins, which can be found in FAC 62-330.

The first step is to determine the required treatment volume per the water management district (WMD) and the County criteria. As this practice is a dry detention based practice, the water quality benefit would be associated with the volume of water that is captured and filtered through the BAM enhanced system. Since this example scenario is located within the SJRWMD boundary, the SJRWMD criteria for dry detention is the relevant water quality criteria for this project. A summary of pre- and post- development conditions are presented below followed by details of the bioretention design, the required treatment volume, and the final size of the system.

- Site conditions summary
  - Pre-development conditions
    - Land use: 3-acre site, pasture
    - Soil types: HSG A/D
  - Post-development conditions
    - Land use:
      - 2.4-acre site high density commercial
      - 0.6 acre will be open space (**20% open space requirement**)

- Soil types: HSG A/D
- Impervious areas:
  - Commercial area will be **60% impervious**
  - 1.8 acres will be impervious
- Proposed LID practice summary
  - Proposed bioretention system is to have the following media layers:
    - 8 inch #57 stone
    - 2 inch #89 stone
    - 2 inch coarse sand
    - 12 inch BAM
    - 6 inch growth media
    - 3 inch hard mulch layer
    - Florida Friendly Landscaping
    - 12 inch ponding layer with 4:1 (H:V) side slopes if fenced, 5:1 if unfenced
  - Since groundwater table and soils are not an appropriate for infiltration at this site, a perforated underdrain with 6 inch diameter is proposed to facilitate system recovery
- Determination of required treatment volume
  - As previously stated, the proposed system is a dry detention practice. Based on the SJRWMD ERP handbook vol. 2 (SJRWMD, 2018), the water quality treatment volume is either a) 1 inch of runoff or b) 2.5 inches of runoff from the impervious area; whichever is greater.
    - a):  $\frac{3 \text{ ac} (1 \text{ in})}{12 \text{ in/ft}} = 0.25 \text{ ac} - \text{ft}$
    - b): 2.5 inches over the impervious area:  $\frac{1.8 \text{ ac} (2.5 \text{ in})}{12 \text{ in/ft}} = 0.375 \text{ ac} - \text{ft}$
    - Since the 2.5 inches of runoff over the impervious area produces the greater treatment volume, this is the value required by the SJRWMD
  - Per the current state special basin criteria, as listed in FAC 62-330, water quality standard, an additional 50% treatment volume is required. This is calculated as:
    - $0.375 \text{ ac} - \text{ft} * 1.5 = 0.5625 \text{ ac} - \text{ft}$
    - Therefore, the total treatment volume required for this project is 0.5625 acre-feet
- Based on the above water quality treatment volume determination, the bioretention system must provide 0.5625 acre-feet of storage. Sizing of the bioretention system is an iterative process where an initial area is assumed and based on the standard section of the proposed system, a provided volume can be determined. This is achieved easiest using a spreadsheet so values can be quickly and easily changed until the treatment volume is achieved.
  - Specifically, each aggregate layer is multiplied by the depth, area, and porosity to determine the water volume provided
  - The ponding volume is determined using the methods presented in **Section 1-2**, above

- Following this process, and assuming a rectangular geometry with 4:1 (H:V) slopes for the ponding volume and a 1 foot freeboard, a total area at top of bank of 0.368 acres was determined.
- Based on this, a rectangular bioretention system with a 8 inch #57 stone layer, 2 inch #89 stone layer, 2 inch coarse sand layer, 12 inch BAM layer, 6 inch growth media layer, 3 inch mulch layer, and 1 foot ponding area (with 4:1 side slopes) would need to be 0.368 acres to provide sufficient treatment for a 3 acre high intensity commercial site.
  - It is noted that the example problem sizing of the bioretention system is only for pollutant treatment purposes, not for flood control purposes. However, the bioretention system will provide some flood control, resulting in a smaller pond needed for flood control elsewhere on the site.
- Since this system has an underdrain, the capacity of the underdrain pipe must be checked to ensure that the pipe can convey the design flow rates. This can be readily calculated using a modified form of the Manning's Equation:

$$d_i = \left( \frac{1630 Q_p n}{\sqrt{S}} \right)^{\frac{3}{8}}$$

where:  $d_i$  = Inside pipe diameter (in)  
 $n$  = Manning's coefficient of roughness  
 $Q_p$  = Peak design discharge rate (cfs)  
 $S$  = Slope of the pipe (ft/ft)

If the pipe cannot convey the peak flow rate, additional head losses must be considered in the recovery time, or a larger size pipe must be used.

## **REFERENCES**

1. Minnesota Stormwater Manual (2022). Soil water storage properties.  
[https://stormwater.pca.state.mn.us/index.php/Soil\\_water\\_storage\\_properties](https://stormwater.pca.state.mn.us/index.php/Soil_water_storage_properties)
2. Woessner, W.W. and Poeter, E. P. (2022). Hydrogeologic Properties of Earth Materials and Principles of Groundwater Flow. ISBN: 978-1-7770541-2-0. <https://gw-project.org/books/hydrogeologic-properties-of-earth-materials-and-principles-of-groundwater-flow/>
3. SFWMD (2016). Environmental Resource Permit Applicant’s Handbook Volume 2.  
[https://www.sfwmd.gov/sites/default/files/documents/swerp\\_applicants\\_handbook\\_vol\\_ii.pdf](https://www.sfwmd.gov/sites/default/files/documents/swerp_applicants_handbook_vol_ii.pdf)
4. SJRWMD (2018). Environmental Resource Permit Applicant’s Handbook Volume 2.  
<https://www.sjrwmd.com/static/permitting/PIM-20180601.pdf>



## **APPENDIX 1A**

# **Bioretention without Underdrains Operation and Maintenance Checklist**

<b>Inspection and Maintenance Checklist for Bioretention without Underdrains</b>			
Facility Name and Address:			
Date of Inspection:			
Site Conditions:            Excellent <input type="checkbox"/> Good <input type="checkbox"/> Adequate <input type="checkbox"/> Poor <input type="checkbox"/>			
Date of Last Rain Event:			
Inspection Frequency Type:    Monthly <input type="checkbox"/> Quarterly <input type="checkbox"/> Annual <input type="checkbox"/>			
<b>Inspection Activities</b>			
Visual inspections are an integral part of system maintenance. Inspection includes monitoring for drainage, debris and sediment accumulation, vegetation health and coverage, and surface deterioration.			
Inspection Item	Checked (Y/N)	Maintenance Needed (Y/N)	Corrective Action/Comments
<b>BIORETENTION SURFACE (Frequency – Monthly)</b>			
BS1. Evidence of erosion (i.e., visible rills or gullies or sediment accumulation)			
BS2. Mulch layer is still in place (depth of at least 3 in)			
BS3. Inflow and overflow points in working order			
<b>VEGETATION MANAGEMENT (Frequency – Quarterly)</b>			
VM1. Evidence of dead or unhealthy plants			
VM2. Is plant community composition still according to approved plans?			
VM3. Do plants appear well maintained/manicured			

<b>SYSTEM PERFORMANCE (Frequency – Monthly)</b>			
SP1. Evidence of standing water			
SP2. Debris and sediment accumulation			
<b>OVERALL CONDITION OF FACILITY</b>			
In accordance with approved design plans? (Y/N)			
Maintenance required as result of deficiencies detailed above? (Y/N)			
Date by which maintenance must be completed: (Y/N)			
<b>NOTES</b>			

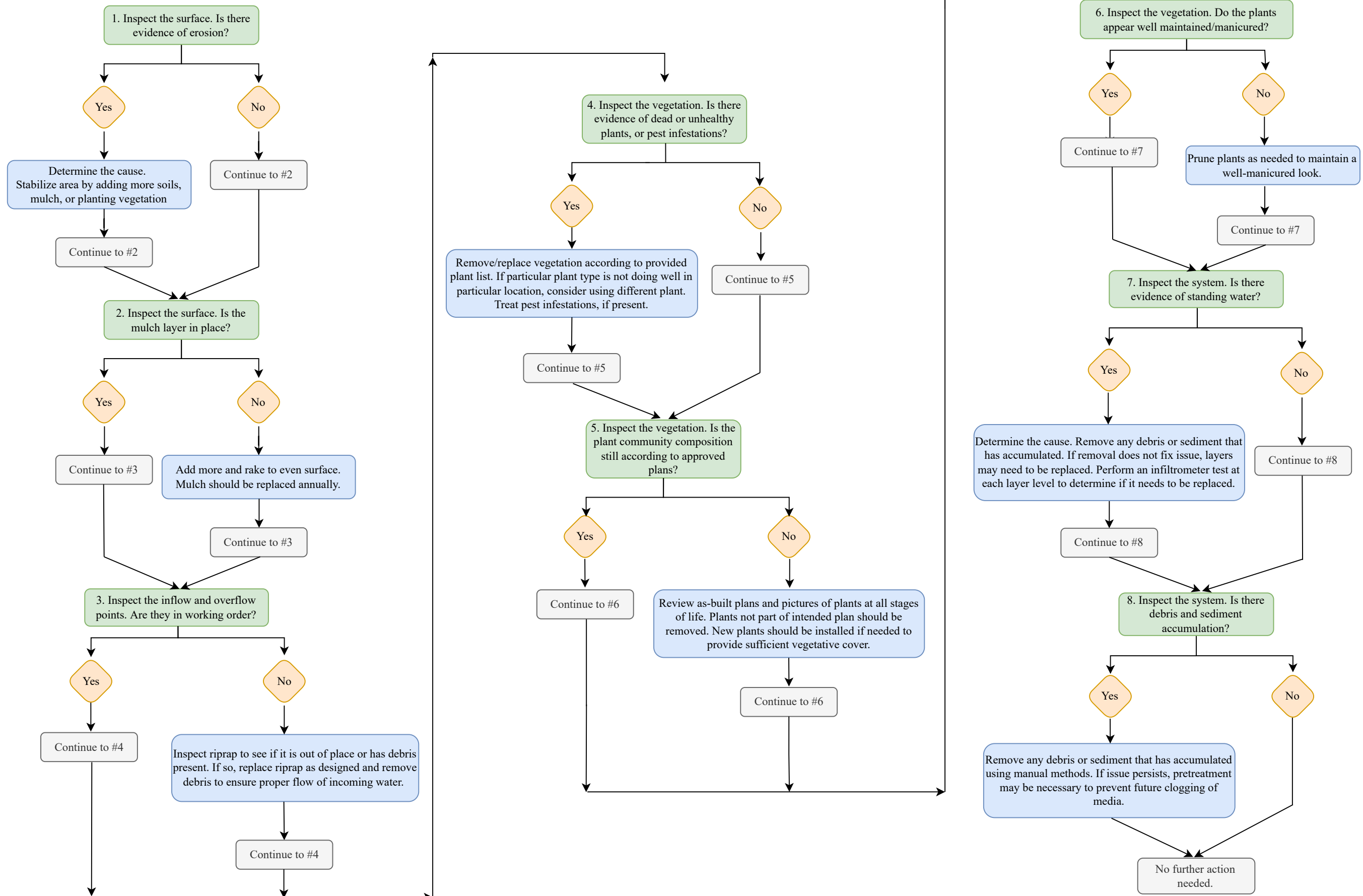
CERTIFICATION SIGNATURE	
Company Name:	
Company email, address, and phone number:	
Name of Inspector:	
Inspector Signature:	

Note: Take a minimum of 5 representative photos of the bioretention area, attach the photos to the form, and include any additional observations in the notes section prior to submission. Make sure to include pictures of any inflow/outflow points, the vegetation, and any other aspects of the bioretention system.

## **APPENDIX 1B**

# **Bioretention without Underdrains Operation and Maintenance Flow Chart**

# Bioretention without Underdrain Operation and Maintenance



## **APPENDIX 1C**

# **Bioretention without Underdrains Water Quality Performance Monitoring Guidance**

## Water Quality Performance Monitoring

To determine if the bioretention system is performing as intended, water quality monitoring should be performed. This includes sampling water at key locations within the bioretention system as well as accumulated sediment and debris removed as part of maintenance activities. To properly monitor this LID practice the pollutant flow path, removal mechanisms, and the downstream waterbody of interest needs to be identified. To aid in the design of a proper bioretention system monitoring program, the general steps below can be followed. It is noted that the below sampling recommendations are relevant for a bioretention system that is installed in a region with a deep groundwater table.

Define the treatment objective and the downstream waterbody of interest. Specifically, determine the water quality parameter(s) of interest and if the goal is to reduce loading to a surface waterbody or groundwater. This will dictate how the practice should be monitored.

- a. If the waterbody of interest is a surface water, then the bulk of the water quality benefit is associated with the volume reduction provided by the practice. Thus, monitoring should focus on characterization of the flow and parameter EMCs of water at the system locations specified below.
  - i. The system inflow
  - ii. The system overflow
- b. Additionally, nutrients and other pollutants can be removed from the system in the form of maintenance activities that are performed, e.g., removal of vegetation, removal of sediments, removal of organic debris. Thus, the mass of pollutants associated with the following should also be characterized.
  - i. Accumulated sediments and organic debris
  - ii. Removed vegetation
- c. If the waterbody of interest is the groundwater, then, in addition to monitoring the inflow to the bioretention system, sampling of the water entering the ground should also be performed.
  - i. To sample water as it enters the ground, a lysimeter is to be installed in the bioretention system so that it can be sampled. Guidance on how to construct and install a lysimeter can be found here: <https://edis.ifas.ufl.edu/publication/AE554>. The sizing of the lysimeter should be based on the desired sample volume so that the lysimeter can hold the anticipated volume.
- d. Flow monitoring should be performed using an area-velocity probe, or other equipment appropriate for continuous estimation of flow, such as the ISCO 2150 area velocity probe.



- e. Stormwater sampling should be performed using auto-sampler equipment capable of collecting time- or flow-weighted composite samples, including but not limited to ISCO 6712 autosamplers. It is noted that, if possible, refrigerated autosamplers are preferred as they are able to preserve samples quicker than field personnel can collect samples.
- f. Storm events that are typical of Central Florida weather are to be sampled to evaluate typical performance of bioretention systems. A rain gauge is to be installed onsite to measure rainfall at the site.
- g. System performance can be determined as the mass that is retained or removed from the bioretention system. This is determined as the difference in the mass entering the system and the mass leaving the system.
  - i. The mass entering the system can be determined based on the flow and constituent EMC. It is noted that while autosamplers are effective at characterizing the fine particulates and dissolved pollutants in stormwater, they are not effective at capturing coarser sediments and organic material. As such, when such materials are removed from bioretention systems as part of maintenance activities, the mass of constituent associated with these activities must be considered as part of the loading to the system as well as loading removed from the system.
  - ii. One mass output is the mass leaving as surface runoff. This can be determined based on the overflow volume and constituent EMC.
  - iii. Another mass output is the mass of pollutants associated with removal of debris, sediments, or vegetation due to maintenance activities performed on the bioretention system. This can be determined based on the mass of material, constituent content, and moisture content of materials removed.
  - iv. The mass leaving to the groundwater can be determined based on the difference in inflow and overflow volume, and the constituent EMC as measured from the lysimeter.
  - v. The performance of the system can be determined based on the difference between the mass entering the bioretention system and the mass discharged to the downstream waterbody of interest.

## **APPENDIX 1D**

# **Bioretention with Underdrains Operation and Maintenance Checklist**

<b>Inspection and Maintenance Checklist for Bioretention with Underdrains</b>			
Facility Name and Address:			
Date of Inspection:			
Site Conditions:            Excellent <input type="checkbox"/> Good <input type="checkbox"/> Adequate <input type="checkbox"/> Poor <input type="checkbox"/>			
Date of Last Rain Event:			
Inspection Frequency Type:    Monthly <input type="checkbox"/> Quarterly <input type="checkbox"/> Annual <input type="checkbox"/>			
<b>Inspection Activities</b>			
Visual inspections are an integral part of system maintenance. Inspection includes monitoring for drainage, debris and sediment accumulation, vegetation health and coverage, and surface deterioration.			
Inspection Item	Checked (Y/N)	Maintenance Needed (Y/N)	Corrective Action/Comments
<b>BIORETENTION SURFACE (Frequency – Monthly)</b>			
BS1. Evidence of erosion (i.e., visible rills or gullies or sediment accumulation)			
BS2. Mulch layer is still in place (depth of at least 3 in)			
BS3. Inflow and overflow points in working order			
<b>VEGETATION MANAGEMENT (Frequency – Quarterly)</b>			
VM1. Evidence of dead or unhealthy plants			
VM2. Is plant community composition still according to approved plans?			
VM3. Do plants appear well maintained/manicured?			

<b>SYSTEM PERFORMANCE (Frequency – Monthly)</b>			
SP1. Evidence of standing water, flushing/vacuuming pipes			
SP2. Debris and sediment accumulation			
<b>OVERALL CONDITION OF FACILITY</b>			
In accordance with approved design plans? (Y/N)			
Maintenance required as result of deficiencies detailed above? (Y/N)			
Date by which maintenance must be completed: (Y/N)			
<b>NOTES</b>			

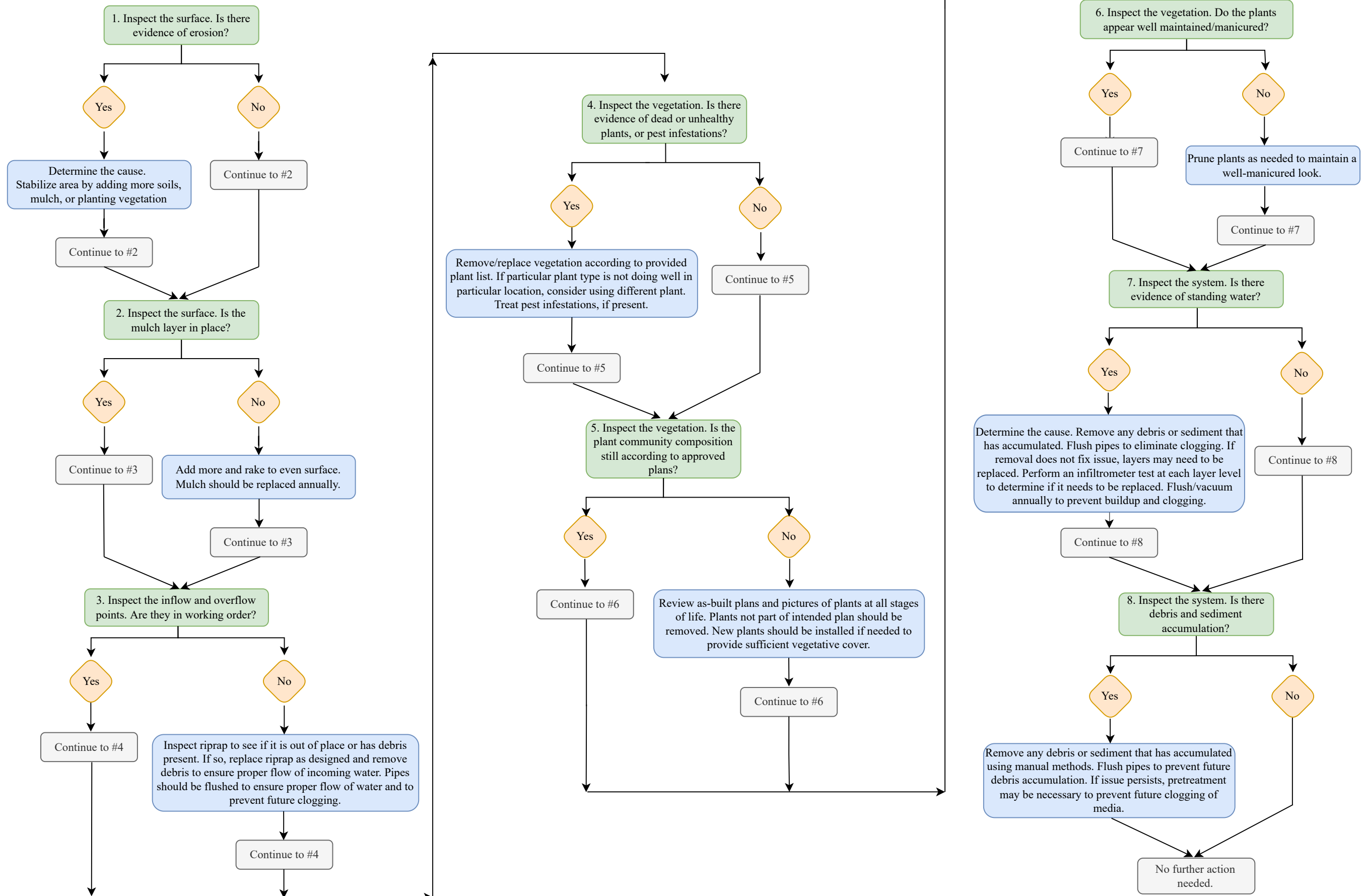
CERTIFICATION SIGNATURE	
Company Name:	
Company email, address, and phone number:	
Name of Inspector:	
Inspector Signature:	

Note: Take a minimum of 5 representative photos of the bioretention area, attach the photos to the form, and include any additional observations in the notes section prior to submission. Make sure to include pictures of any inflow/outflow points, the vegetation, and any other aspects of the bioretention system.

## **APPENDIX 1E**

# **Bioretention with Underdrains Operation and Maintenance Flow Chart**

# Bioretention with Underdrain Operation and Maintenance



## **APPENDIX 1F**

# **Bioretention with Underdrains Water Quality Performance Monitoring Guidance**



## Water Quality Performance Monitoring

To determine if the bioretention system is performing as intended, water quality monitoring should be performed. This includes sampling water at key locations within the bioretention system as well as accumulated sediment and debris removed as part of maintenance activities. To properly monitor this LID practice the pollutant flow path, removal mechanisms, and the downstream waterbody of interest needs to be identified. To aid in the design of a proper bioretention system monitoring program, the general steps below can be followed. It is noted that the below sampling recommendations are relevant for a bioretention system that is installed in a region with a seasonal high groundwater table.

Define the treatment objective and the downstream waterbody of interest. Specifically, determine the water quality parameter(s) of interest and if the goal is to reduce loading to a surface waterbody or groundwater. This will dictate how the practice should be monitored.

- a. If the waterbody of interest is a surface water, then the bulk of the water quality benefit is associated with the volume reduction provided by the practice. Thus, monitoring should focus on characterization of the flow and parameter EMCs of water at the system locations specified below.
  - i. The system inflow
  - ii. The system overflow
- b. Additionally, nutrients and other pollutants can be removed from the system in the form of maintenance activities that are performed, e.g., removal of vegetation, removal of sediments, removal of organic debris. Thus, the mass of pollutants associated with the following should also be characterized.
  - i. Accumulated sediments and organic debris
  - ii. Removed vegetation
- c. If the waterbody of interest is the groundwater, then, in addition to monitoring the inflow to the bioretention system, sampling of the water entering the ground should also be performed.
  - i. To sample water as it enters the ground, a lysimeter is to be installed in the bioretention system so that it can be sampled. Guidance on how to construct and install a lysimeter can be found here: <https://edis.ifas.ufl.edu/publication/AE554>. The sizing of the lysimeter should be based on the desired sample volume so that the lysimeter can hold the anticipated volume.
- d. Flow monitoring should be performed using an area-velocity probe, or other equipment appropriate for continuous estimation of flow, such as the ISCO 2150 area velocity probe.

- e. Stormwater sampling should be performed using auto-sampler equipment capable of collecting time- or flow-weighted composite samples, including but not limited to ISCO 6712 autosamplers. It is noted that, if possible, refrigerated autosamplers are preferred as they are able to preserve samples quicker than field personnel can collect samples.
- f. Storm events that are typical of Central Florida weather are to be sampled to evaluate typical performance of bioretention systems. A rain gauge is to be installed onsite to measure rainfall at the site.
- g. System performance can be determined as the mass that is retained or removed from the bioretention system. This is determined as the difference in the mass entering the system and the mass leaving the system.
  - i. The mass entering the system can be determined based on the flow and constituent EMC. It is noted that while autosamplers are effective at characterizing the fine particulates and dissolved pollutants in stormwater, they are not effective at capturing coarser sediments and organic material. As such, when such materials are removed from bioretention systems as part of maintenance activities, the mass of constituent associated with these activities must be considered as part of the loading to the system as well as loading removed from the system.
  - ii. One mass output is the mass leaving as surface runoff. This can be determined based on the overflow volume and constituent EMC.
  - iii. Another mass output is the mass of pollutants associated with removal of debris, sediments, or vegetation due to maintenance activities performed on the bioretention system. This can be determined based on the mass of material, constituent content, and moisture content of materials removed.
  - iv. The mass leaving to the groundwater can be determined based on the difference in inflow and overflow volume, and the constituent EMC as measured from the lysimeter.
  - v. The performance of the system can be determined based on the difference between the mass entering the bioretention system and the mass discharged to the downstream waterbody of interest.

# **ATTACHMENT 2**

## **BAM Enhancements**



engineers | scientists | innovators



# STORMWATER LOW IMPACT DEVELOPMENT MANUAL, VOLUME 2

## ATTACHMENT 2

# BAM Enhancements

*Prepared for*

**Orange County Planning Division**

201 S. Rosalind Ave., 2<sup>nd</sup> Floor  
Orlando, FL 32802

**Orange County Public Works**

4200 S John Young Parkway  
Orlando, FL 32839

**Orange County Environmental Protection Division**

3165 McCrory Place, Suite 200  
Orlando, FL 32803

*Prepared by*

Geosyntec Consultants, Inc.  
3504 Lake Lynda Drive, Suite 155  
Orlando, FL 32817

Project Number: FW8213

December 2023

## TABLE OF CONTENTS

2.	BACKGROUND .....	2-1
2.1	Design Features of Typical System.....	2-1
2.2	Design Guidance and Criteria .....	2-2
2.3	Site Suitability .....	2-4
2.4	Pollutant Removal Efficiencies .....	2-4
2.5	Regulatory and Permitting Considerations.....	2-5
2.6	Construction Considerations .....	2-5
2.7	Design Details and Specifications .....	2-6
2.8	Inspection, Maintenance, and Monitoring.....	2-9
2.8.1	Inspection Steps and Checklist for BAM Enhancement Systems without Underdrains .....	2-9
2.8.2	Water Quality Performance Monitoring Guidance for BAM Enhancement Systems without Underdrains.....	2-11
2.8.3	Inspection Steps and Checklists for BAM Enhancement Systems with Underdrains .....	2-11
2.8.4	Water Quality Performance Monitoring Guidance for BAM Enhancement Systems with Underdrains.....	2-14
2.9	Design Calculations Example for Well-Draining Sandy Soils .....	2-14
2.10	Design Calculations Example for Poor-Draining / High Water Table Soils or Sensitive Groundwater Areas.....	2-16

## LIST OF TABLES

Table 2-1.	Porosity of Materials used in BAM Enhancement Areas.....	2-3
------------	--	-----

## LIST OF FIGURES

Figure 2-1:	BAM with Deep Groundwater Table Details .....	2-7
Figure 2-2:	BAM with Shallow Groundwater Table Details.....	2-8

## **LIST OF ATTACHMENTS**

- Appendix 2A: BAM without Underdrains Operation and Maintenance Checklist
- Appendix 2B: BAM without Underdrains Operation and Maintenance Flow Chart
- Appendix 2C: BAM without Underdrains Water Quality Monitoring Guidance
- Appendix 2D: BAM with Underdrains Operation and Maintenance Checklist
- Appendix 2E: BAM with Underdrains Operation and Maintenance Flow Chart
- Appendix 2F: BAM with Underdrains Water Quality Monitoring Guidance

## ACRONYMS AND ABBREVIATIONS

BAM	Biosorption Activated Media
BMAP	Basin Management Action Plan
BMP	Best Management Practice
CEC	Cation Exchange Capacity
DCIA	Directly Connected Impervious Area
DEM	Digital Elevation Model
EMC	Event Mean Concentration
EPA	Environmental Protection Agency
ERP	Environmental Resource Permit
FAC	Florida Administrative Code
FDEP	Florida Department of Environmental Protection
GSI	Green Stormwater Infrastructure
H&H	Hydrologic and Hydraulic Modeling
ICPR4	Interconnected Channel and Pond Routing Model
LID	Low Impact Development
MS4	Municipal Separate Storm Sewer System
N <sub>2</sub>	Nitrogen Gas
NH <sub>3</sub>	Ammonia
NO <sub>2</sub>	Nitrite
NO <sub>3</sub>	Nitrate
NOAA	National Oceanic and Atmospheric Administration
NPDES	National Pollutant Discharge Elimination System
NWL	Normal Water Level
OFS	Outstanding Florida Springs
OFW	Outstanding Florida Waters
PFA	Primary Focus Area
RAP	Reasonable Assurance Plan
SFWMD	South Florida Water Management District
SJRWMD	St. Johns River Water Management District
SWMM	Storm Water Management Model
SWMP	Stormwater Management Program

Tc	Time of Concentration
TMDL	Total Maximum Daily Load
TN	Total Nitrogen
TP	Total Phosphorus
UF/IFAS	University of Florida/Institute of Food and Agricultural Sciences
VBS	Vegetated Buffer Strips
WERF	Water Environment Research Foundation
WMD	Water Management District



## 2. BACKGROUND

This attachment provides more detailed information on biosorption activated media (BAM). Design features of typical systems, as well as design guidance and criteria, are presented and discussed. Additionally, site suitability, pollutant removal efficiencies, regulatory and permitting considerations, construction considerations, and design details and specifications are presented. Finally, two example problems are presented to demonstrate design calculations for BAM systems in areas with poor draining soils/elevated water tables and areas with well draining soils/deep water tables. It should be noted that BAM layers can also be used in other LID practices to enhance pollutant removal.

### 2.1 Design Features of Typical System

BAM enhancement systems can be designed similarly to traditional retention systems, where they store and infiltrate water, or as a detention system, where they contain an underdrain to collect water that has been filtered through system aggregate layers including a BAM layer. However, one distinguishable feature is having an engineered media layer that provides extra nutrient removal. BAM enhancement systems discussed in this manual have two primary designs discussed above, namely one without an underdrain and one with an underdrain. BAM enhancement systems without an underdrain are typically used in applications where the system has 3 feet or more of separation between the bottom of the basin and the SHGWT. These systems typically contain the following layers as a minimum, from system bottom to top:

- 2 inches (minimum) of coarse sand (this optional layer can add to the water storage of the system),
- 1 foot (minimum) of BAM (this optional layer can be added to protect sensitive groundwater conditions),
- 6 inches (minimum) of top soil, and
- Sod to be planted on top of the top soil.

The maximum slope from the top of bank to the pond bottom is 4:1 (H:V) if fenced and 5:1 if unfenced. The points of inflow and outflow should leverage hard or soft armoring techniques to protect against erosion. Florida native sod appropriate for the expected conditions, i.e., water depth/duration, amount of light, etc. are to be planted in the BAM system. Refer to **Appendix A** of the accompanying Volume 1 of this LID manual for plant lists appropriate for the different conditions found within the County as well as guidance on choosing trees based on soil volume available.

For a BAM system that does not have 3 feet of separation between the bottom of the basin and the SHGWT, or has poor infiltrating soils, an underdrain is required to provide recovery for the system. These systems typically have the following layers as a minimum, from system bottom to top:

- 8 inches (minimum) of #57 gravel envelope,
- 2 inches (minimum) of #89 gravel envelope,

- 2 inches (minimum) of coarse sand,
- 1 foot (minimum) of BAM, and
- 4 inches (minimum) of coarse sand.

These are examples of stone gradations that can be used, however, other stone gradations can also be used. It is noted that should other stone gradations be used, they need to be selected such that the pore sizes of the base are not sufficiently large to allow the top layer to fill in voids. Some mixing at the interface is normal but a subsequent layer should be able to be built up. The intent of the different stone bridging layers is to eliminate the need for filter fabrics since they are prone to clogging. This is due to the fact that this practice/media encourages the growth of biofilm, which while enhances nutrient removals, it can choke out pores if it concentrates along filter fabric interface.

A geotextile filter fabric should be installed on the sides and bottom of the BAM system to minimize mixing with parent soils. An underdrain, minimum 6 inch diameter perforated pipe, should be installed to collect water that percolates through the system and direct the collected water to the existing drainage system.

The maximum slope from the top of bank to the normal water level (NWL) line should be 4:1 (H:V) if fenced and 5:1 if unfenced. The maximum slope from the NWL to the bank bottom should be 2:1 (H:V). The points of inflow should leverage hard or soft armoring techniques to protect against erosion. Florida native plants appropriate for the expected conditions, i.e., water depth/duration, amount of light, etc. are to be planted along the edges of the BAM system. Refer to **Appendix A** of the accompanying Volume 1 of this LID manual for plant lists appropriate for the different conditions found within the County as well as guidance on choosing trees based on the soil volume available.

## 2.2 Design Guidance and Criteria

BAM enhancement systems are typically used to help reduce the volume of runoff leaving a site by providing ponding area for runoff to be detained and provide filtration and sorption of pollutants by the plants and different media layers. While these systems can alleviate flooding, they will often by themselves not have the capacity to provide the site flood storage requirements, as the main priority is to provide filtration. While these systems are typically incorporated into a design to meet a water quality criteria, the volume provided can be used to off-set flood control volume requirements. Based on this, sizing of these systems will be based on the required water quality treatment that must be provided. This sets forth a presumptive criteria that water quality targets are being met if this level treatment is provided. The design example presented below demonstrates the calculation methodology necessary to determine the appropriate water quality treatment volume.

BAM enhancement systems are composed of specific materials that each serve a specific function within the system. Rock aggregate layers provide water storage, facilitate drainage, provide bridging layers to minimize movement of different materials to different layers, and evenly distribute water. The coarse sand layer performs similar functions as the rock aggregate layers,

providing some water storage, bridging, and facilitating drainage. The water storage associated with these layers can be determined by multiplying the material depth by the area and the porosity (Table 2-1).

**Table 2-1. Porosity of Materials used in BAM Enhancement Areas**

Material	Recommended Porosity Value	Reference
#89 Stone	25%	BMPTrains, 2020, v4.3.2
#57 Stone	21%	BMPTrains, 2020, v4.3.2
Coarse Sand	18%	Woessner & Poeter, 2020
BAM	20%	BMPTrains, 2020, v4.3.2
Mulch	70%	Sustainable Technologies, 2022
Growth Media (Sandy Loam)	14%	Minnesota Stormwater Manual, 2022

The ponding volume on top of the mulch layer can be determined using the equation below:

$$(A_1 \times D) + \left( (A_2 - A_1) \times D \times \frac{1}{2} \right) = V$$

Where:

$A_1$  = Area of the bottom slice of the ponding depth (ft<sup>2</sup>)

$A_2$  = Area of the top slice of the ponding depth (ft<sup>2</sup>)

D = Ponding depth (ft)

V = Volume of the ponding area (ft<sup>3</sup>)

Florida Friendly Landscaping should be leveraged and appropriate plants chosen based on the expected conditions. Since BAM enhancement systems often use sod in and around the pond and bank, it is recommended that a Florida native sod is chosen. The plant lists supplied in **Appendix A** of the accompanying Volume 1 of this LID manual should be referred for guidance on plant selection as well as guidance on choosing trees based on soil volume available.

Finally, some additional considerations are related to how water enters or leaves these systems. Inflow points should be protected using either a hard or soft armoring approach, depending on the anticipated flow rates and velocities. The State of Florida Erosion and Sediment Control Designer and Reviewer Manual (July 2013) provides guidance on acceptable velocities for different armoring practices. BAM enhancement systems in areas that incorporate an underdrain into the

design must ensure that sufficient underdrains be provided to drain the treatment volume within 72 hours (SFWMD, 2016; SJRWMD, 2018). This can be checked using a modified version of the Manning's Equation:

$$d_i = \left( \frac{1630 \times Q_p \times n}{\sqrt{S}} \right)^{3/8}$$

Where:

$d_i$  = Inside pipe diameter (in)

$n$  = Manning's coefficient of roughness

$Q_p$  = Peak discharge rate (cfs)

$S$  = Slope of pipe (ft/ft)

### 2.3 Site Suitability

BAM enhancement systems should be strategically placed based on site conditions. Existing retention or detention systems can be retrofitted to include BAM. Additionally, BAM system design should incorporate an underdrain for systems that have less than 3 feet of separation between the SHGWT and the system bottom. As stated previously, BAM may be used in many BMPs to increase the nutrient reduction potential.

Additionally, the built-out conditions must be considered, for example, the system should be sited at a minimum of 10 feet away from structures to prevent damage due to seepage or flooding. It is good engineering practice to consider other infrastructure that could be impacted by the proposed BAM enhancement such as road bases and/or building foundations. It should be noted that even with the use of a root barrier, the "right plant, right place" practice should be prioritized over the dependence on a root barrier to prevent underground damage. For example, it is possible for roots to grow both over and under this barrier. Additionally, nearby wastewater treatment practices should be considered and infiltrating practices, such as BAM enhancement systems, should not be placed over a septic drainfield and must be at least 75 feet away from public or private potable wells.

### 2.4 Pollutant Removal Efficiencies

The pollutant removal efficiency for BAM enhancement systems is based on the removal mechanisms of this practice. In areas where stormwater can be infiltrated and are not within sensitive groundwater areas, it is assumed that the pollutants associated with the water that infiltrates into the ground are removed. If the area has sensitive groundwater conditions and loadings to the groundwater is of interest, such as the Wekiwa Springs PFA, a BAM layer is recommended to provide treatment of water as it infiltrates into the ground and the removal efficiency relies on the characteristics of the BAM layer. To determine the water quality benefit, estimate the average annual volume of water infiltrated into the ground, multiply by the appropriate

event mean concentration (EMC), and then multiply by the removal efficiency of the pollution control media used. The average annual volume of water infiltrated can be estimated by leveraging continuous simulation modeling or the methods of Harper and Baker (2007). Additionally, there are models and calculation tools that are based on the Harper and Baker (2007) method, such as the BMP Trains model, which can be used to estimate the water quality benefit of implementing BAM enhancement systems.

## 2.5 Regulatory and Permitting Considerations

Applicable criteria for the governing water management district are to be applied on a site by site basis. It is anticipated that BAM projects will require an Environmental Resource Permit (ERP) from the corresponding water management district (SFWMD, 2016; SJRWMD, 2018). For a project to qualify for an ERP it must be demonstrated that the proposed project will not result in upstream flooding or increases in peak stage, or not result in increases in peak discharge rates from the site, as well as meet water quality treatment requirements. It is noted that stormwater treatment performance standards vary depending on a number of site factors and are summarized as follows:

- If the proposed system discharges directly/indirectly to surface waters, it falls under the MS4 and NPDES rules,
- If the proposed system discharges directly to an Outstanding Florida Waterbody (OFW) or Outstanding Florida Springs (OFS), it falls under the FDEP OFW and OFS rule,
- If the proposed system is within waterbodies with TMDLs, it falls under the EPA rule which delegates the enforcing authority to FDEP, and
- If the proposed system is within watersheds that are on the verified impaired waterbodies list, sensitive groundwater areas, or waterbodies with BMAPS, 4b, or 4e plans, it falls under the FDEP rule.

The specific water quality treatment volume required varies depending on the criteria listed above. Additionally, for basins that do not currently require that additional 50% treatment volume, this manual requires the criteria be provided in all basins in Orange County, in addition to the relevant water management district requirements. This requirement may be affected by the pending statewide stormwater rule and should be evaluated after adoption of the rule, as this manual was started prior to the adoption of the statewide stormwater rule.

## 2.6 Construction Considerations

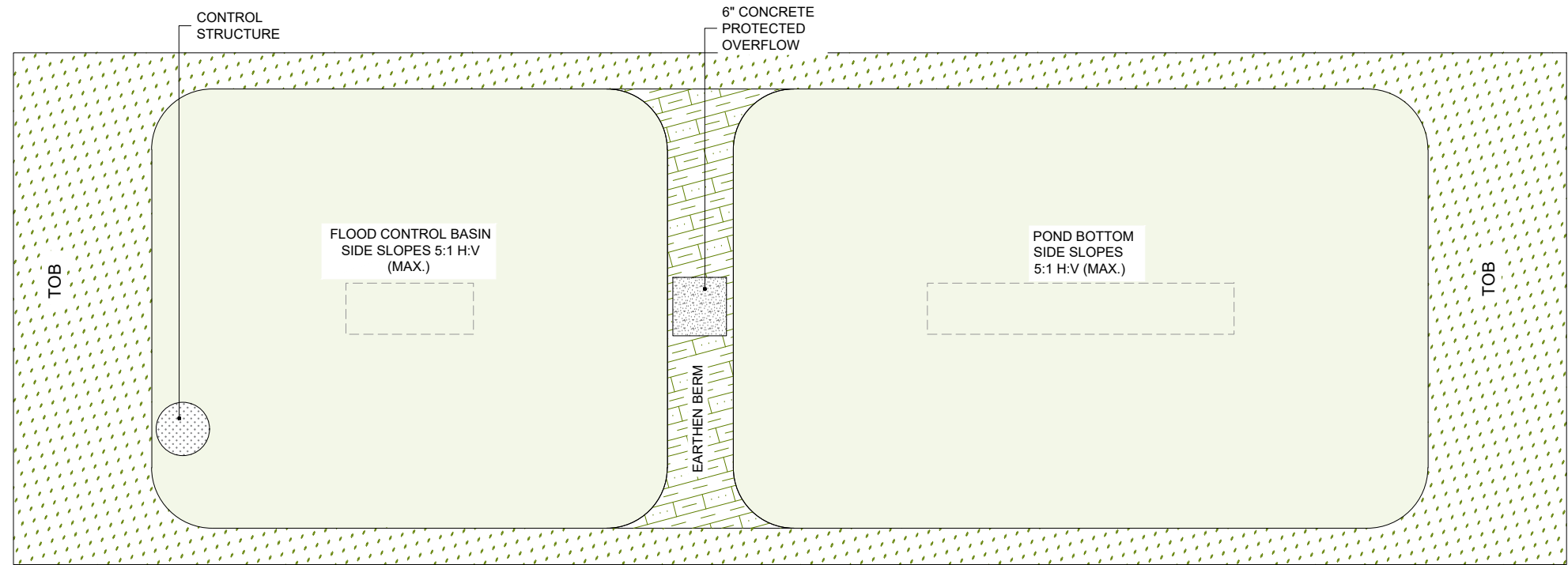
The following construction considerations should be considered when building a BAM system:

- Utilities should be contacted prior to digging to ensure it is clear to dig, otherwise relocation of the utilities will be necessary. The area to be excavated should be determined based on calculations done to meet nutrient removal needs.
  - No utility or other infrastructure shall be placed in the location of the LID structure that would interfere with the function or maintenance of the structure.

- Every effort should be made to minimize compaction of soils where the BAM system is proposed,
- A sufficient staging area should be provided where:
  - Plants can get sufficient sunlight and be easily watered to keep them alive prior to planting, and
  - BAM media, coarse sand and topsoil, and rock aggregates can be stored without risk of contamination or mixing with site soils.
- Appropriate erosion and sediment control practices be incorporated to minimize site erosion and sediment loss

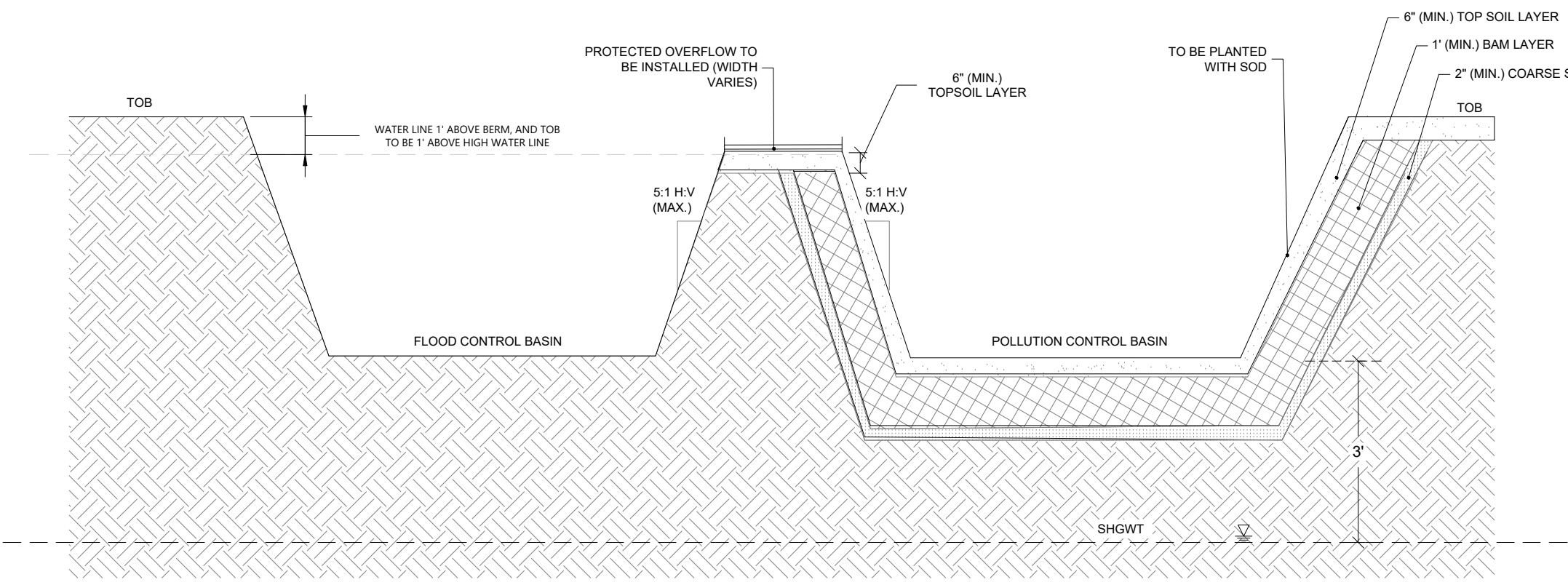
## 2.7 Design Details and Specifications

As part of this effort, design details and general specifications were developed. **Figure 2-1** and **Figure 2-2** show the relevant design details for BAM enhancement systems both without and with an underdrain. General specifications are also included on each detail.



- NOTES:**
1. THIS DESIGN IS INTENDED FOR SENSITIVE GROUNDWATER APPLICATION.
  2. IF POND SLOPES ARE 5:1 (H:V) OR LESS, NO FENCE IS REQUIRED. IF POND SLOPES ARE 4:1 (H:V) OR STEEPER, A FENCE IS REQUIRED..
  3. CONTACT UTILITY COMPANY AND ENSURE UTILITY LINES ARE PROPERLY LOCATED PRIOR TO DIGGING OR TRENCHING.
  4. FOR EXISTING TREES, CONSULT A PROFESSIONAL ARBORIST IF ROOT TRIMMING IS REQUIRED.
  5. THE TOP SOIL IS INTENDED TO PROMOTE INFILTRATION AS WELL AS HEALTHY SOD GROWTH. GROWTH MEDIA SHALL BE A MINIMUM OF 6 INCHES IN DEPTH AND HAVE A MINIMUM ORGANIC COMPOST CONTENT OF 15%. TOP SOIL SHALL ACHIEVE INFILTRATION RATES THAT EXCEEDS 2 INCHES PER HOUR. TOP SOIL AND COMPOST TO BE FREE FROM OBJECTIONABLE WEEDS, LITTER, STIFF CLAY, STONES, ROOTS, TRASH, HERBICIDES, TOXIC SUBSTANCES, OR ANY OTHER CHEMICAL THAT MAY BE HARMFUL TO THE ENVIRONMENT.
  6. THE BAM LAYER IS INTENDED TO PROVIDE TN AND TP REMOVAL FROM STORMWATER AS IT INFILTRATES INTO THE GROUND. THIS LAYER IS INTENDED TO BE USED IN AREAS OF SENSITIVE GROUNDWATER, SUCH AS WITHIN THE WEKIWA SPRINGS SPRINGSHED. BAM IS A GENERIC TERM FOR ANY MEDIA THAT LEVERAGES BIOLOGICAL, CHEMICAL, AND/OR PHYSICAL PROCESSES FOR POLLUTANT REMOVAL. MEDIA SHALL ACHIEVE INFILTRATION RATES THAT EXCEEDS 2 INCHES PER HOUR.
  7. THE COARSE SAND LAYER IS INTENDED TO ACT AS A SUPPORT LAYER FOR THE BAM AND PROVIDE A BRIDGING LAYER TO PREVENT THE MIGRATION OF BAM MEDIA FROM ENTERING THE STONE RESERVOIR LAYERS BELOW. THE COARSE SAND SHOULD BE WASHED AND CONSISTENT WITH ASTM C-33. SAND SHALL BE FREE FROM OBJECTIONAL WEEDS, LITTER, SODS, STIFF CLAY, STONES, ROOTS, TRASH, HERBICIDES, TOXIC SUBSTANCES, OR ANY OTHER CHEMICAL THAT MAY BE HARMFUL TO THE ENVIRONMENT.
  8. THIS CAN BE A HARD ARMORING APPROACH, SUCH AS CONCRETE WITH 6" OF THICKNESS.
  9. FLOOD AND POLLUTION CONTROL VOLUMES TO BE SIZED ACCORDING TO APPLICABLE REGULATORY CRITERIA.
  10. IF TRYING TO MAINTAIN TREES ON SITE, MAKE SURE MAINTENANCE EFFORTS ARE IN LINE WITH ARBORIST REQUIREMENTS.
  11. FREEBOARD IS 1' ABOVE THE DESIGN HIGH WATER, WHICH IS ALSO THE FLOOD CONTROL VOLUME (FCV).

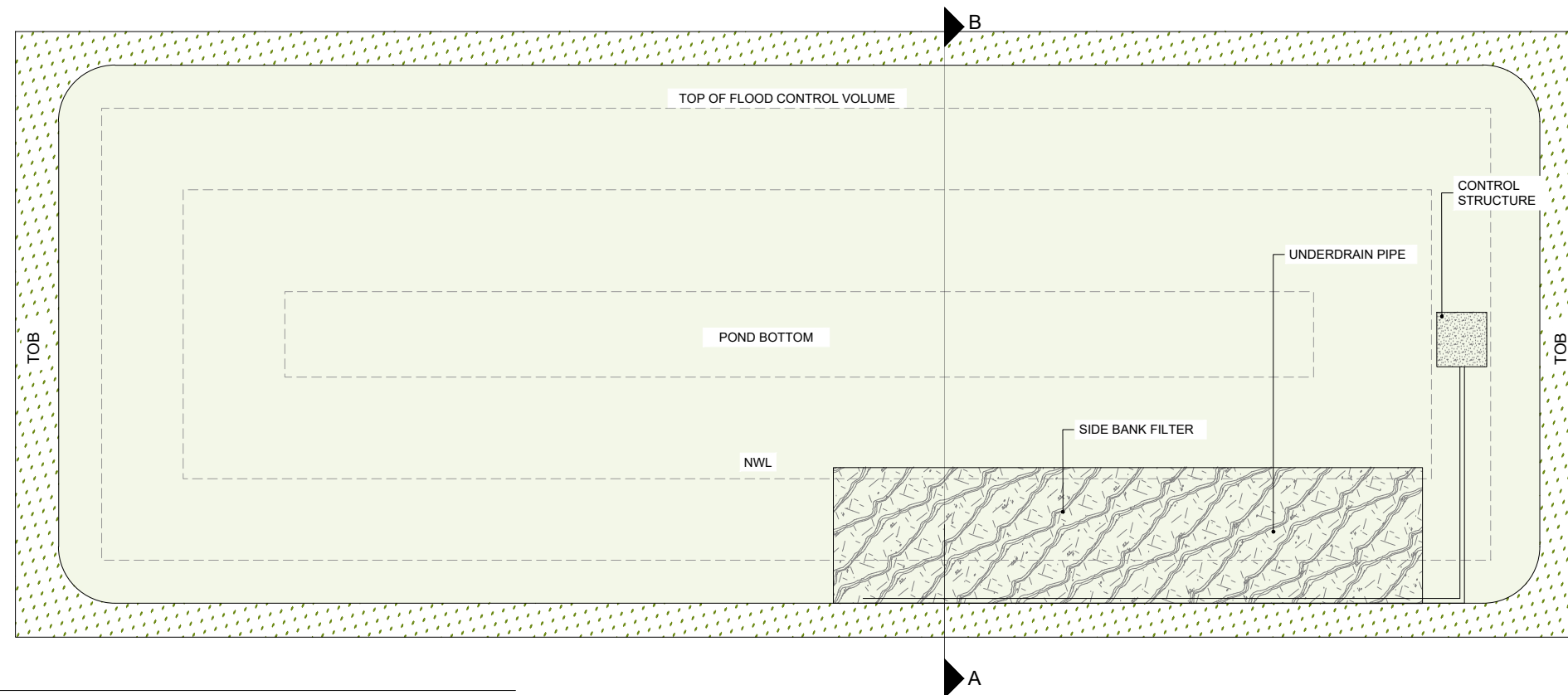
**PLAN**  
**BAM ENHANCEMENT POND WITH DEEP GROUNDWATER TABLE**  
 (NOTE)  
 N.T.S.



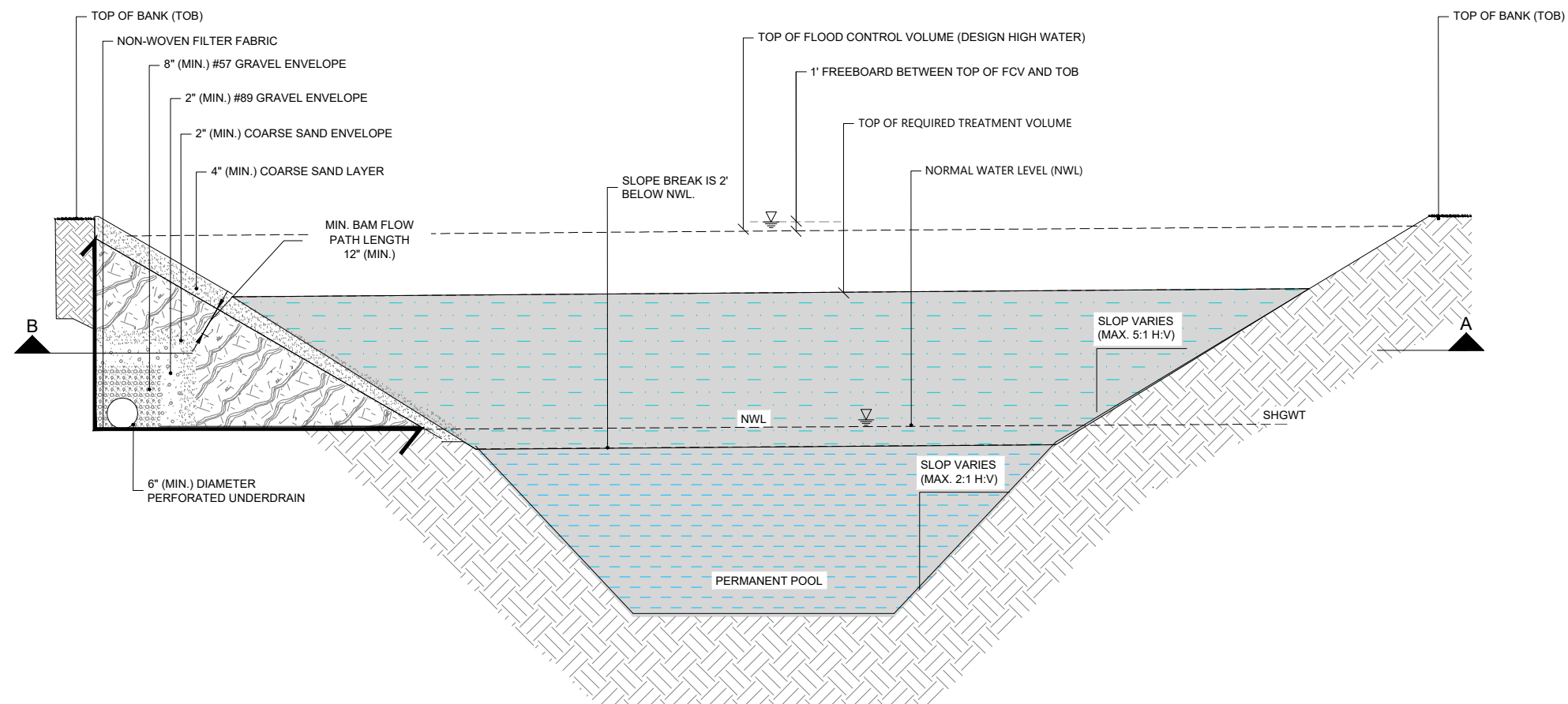
**SECTION**  
**BAM ENHANCEMENT POND WITH DEEP GROUNDWATER TABLE**  
 (NOTE)  
 N.T.S.

**BAM ENHANCEMENT POND WITH DEEP GROUNDWATER TABLE**  
**LID MANUAL DETAILS**  
**ORANGE COUNTY; FLORIDA**

Geosyntec consultants  **FIGURE 2-1**



**PLAN**  
**BAM ENHANCEMENT POND WITH SHALLOW GROUNDWATER TABLE**  
 (NOTE)  
 SCALE: N.T.S.



**SECTION**  
**BAM ENHANCEMENT POND WITH SHALLOW GROUNDWATER TABLE**  
 (NOTE)  
 SCALE: N.T.S.

**NOTES:**

1. FREEBOARD IS 1' ABOVE THE DESIGN HIGH WATER, WHICH IS ALSO THE FLOOD CONTROL VOLUME (FCV).
2. CONTACT UTILITY COMPANY AND ENSURE UTILITY LINES ARE PROPERLY LOCATED PRIOR TO DIGGING OR TRENCHING.
3. FOR EXISTING TREES, CONSULT A PROFESSIONAL ARBORIST IF ROOT TRIMMING IS REQUIRED.
4. THE BAM LAYER IS INTENDED TO PROVIDE TN AND TP REMOVAL FROM STORMWATER BEFORE IT IS COLLECTED BY THE UNDERDRAIN PIPE. BAM IS A GENERIC TERM FOR ANY MEDIA THAT LEVERAGES BIOLOGICAL, CHEMICAL, AND/OR PHYSICAL PROCESSES FOR POLLUTANT REMOVAL. MEDIA SHALL ACHIEVE INFILTRATION RATES THAT EXCEEDS 2 INCHES PER HOUR.
5. THE COARSE SAND LAYER IS INTENDED TO ACT AS A SUPPORT LAYER FOR THE BAM AND PROVIDE A BRIDGING LAYER TO PREVENT THE MIGRATION OF BAM MEDIA FROM ENTERING THE STONE RESERVOIR LAYERS BELOW. THE COARSE SAND SHOULD BE WASHED AND CONSISTENT WITH ASTM C-33. SAND SHALL BE FREE FROM OBJECTIONAL WEEDS, LITTER, SODS, STIFF CLAY, STONES, ROOTS, TRASH, HERBICIDES, TOXIC SUBSTANCES, OR ANY OTHER CHEMICAL THAT MAY BE HARMFUL TO THE ENVIRONMENT.
6. THE #89 STONE LAYER IS INTENDED TO ACT AS A BRIDGING LAYER TO INCREASE WATER STORAGE WITHIN THE SYSTEM. THE AGGREGATE SIZING SHOULD BE CONSISTENT WITH AASHTO M 43, WITH A NOMINAL DIAMETER OF 3/8 OF AN INCH. ALL AGGREGATE STONE IS TO BE WASHED TO MINIMIZE THE INTRODUCTION OF FINES INTO THE SYSTEM.
7. THE #57 STONE LAYER IS INTENDED TO ACT AS A DRAINAGE LAYER TO FACILITATE WATER COLLECTION BY THE UNDERDRAIN WHILE ALSO INCREASING THE WATER STORAGE OF THE SYSTEM. THE AGGREGATE SIZING SHOULD BE CONSISTENT WITH AASHTO M43, WITH A NOMINAL DIAMETER OF 1.5 INCHES. ALL AGGREGATE STONE IS TO BE WASHED TO MINIMIZE THE INTRODUCTION OF FINES INTO THE SYSTEM.
8. THE OVERFLOW WILL BE DISCHARGED FROM THE POND VIA THE POND CONTROL STRUCTURE AND SHOULD BE DESIGNED ACCORDING TO THE MOST RECENT REGULATORY CRITERIA.
9. THE PVC UNDERDRAIN PIPE IS TO CONSIST OF A SLOTTED OR PERFORATED PIPE WRAPPED IN A NON-WOVEN FILTER FABRIC AND BE INSTALLED CONSISTENT WITH FDOT STANDARD PLANS INDEX 440-001.
10. WHENEVER PIPE DIRECTION CHANGES, THERE NEEDS TO BE A TWO-WAY CLEAN-OUT STRUCTURE.

BAM ENHANCEMENT POND WITH SHALLOW GROUNDWATER TABLE

LID MANUAL DETAILS

ORANGE COUNTY; FLORIDA



FIGURE  
 2-2



## 2.8 Inspection, Maintenance, and Monitoring

Operation of BAM enhancement systems requires adequate maintenance to ensure proper function. This includes frequent inspections to identify maintenance issues, performance monitoring, and general weeding/debris removal. This attachment provides detailed information on the operation and maintenance required to ensure proper function of BAM enhancement systems. This attachment includes an inspection and maintenance checklist that goes over site conditions, various inspection items, and allows maintenance personnel to note if maintenance is needed and what corrective actions are recommended (**Appendix 2A** and **2D**). A flow chart is included to be used in tandem with the checklist, as it provides step by step action items to guide the maintenance personnel through the task (**Appendix 2B** and **2E**). The numbered items on the flow chart correspond to the numbered items in the checklist. Additionally, optional monitoring guidance is provided in **Appendix 2C** and **2F**.

The maintenance personnel are required to take a minimum of five photographs as well as notes describing the conditions of the BAM area. It is noted that five baseline photos should be taken of the BAM system after construction is complete. Guidance on where the photos should be taken can be found at the end of **Appendix 2B** and **2E**. The notes should elaborate on any of the topics listed in the checklist but can also cover other observations made or actions taken that the maintenance personnel deems important. The maintenance checklists are required to be submitted annually to the County at an agreed upon date to ensure that the BAM system is being regularly maintained. Every 5 years, a professional engineer must check the system to ensure that it is functioning as designed and sign off on its performance. An alternative maintenance plan and/or schedule may be used with approval from the County engineer.

### 2.8.1 Inspection Steps and Checklist for BAM Enhancement Systems without Underdrains

This section provides steps, a checklist, and a flow chart for maintenance personnel to use while inspecting BAM enhancement systems without underdrains. The checklist can be found in **Appendix 2A** and the flow chart can be found in **Appendix 2B**. A plan sheet for each site is to be included with every inspection sheet and it is encouraged that the maintenance personnel mark up the plan sheet as needed. Inspection includes the system surface, vegetation, and overall system performance. To aid the inspector during the maintenance process and in completing the checklist, the necessary inspection and maintenance activities are described below.

#### 2.8.1.1 BAM System Surface Activities

Inspection of system surface activities includes inspecting the BAM system for evidence of erosion and if the inflow and overflow points are free of debris. The below descriptions are intended to provide more detailed information on the specific action items for BAM surface inspection noted in the check list.

**BS1:** BAM enhancement systems should have all their surface areas inspected monthly for evidence of erosion. If there is evidence of erosion, such as rills or gullies or accumulation of sediments, the impacted areas should be restored and incorporation of erosion and

sediment control products to protect against erosive forces should be considered. This can include stabilization practices such as rolled erosion control products, hard armoring, riprap, or the incorporation of additional vegetation to protect soils and slow the velocity of the incoming water.

- BS2:** BAM enhancement systems inflow and overflow points should be inspected monthly to determine if the inflow and overflow points are in working order. If riprap is used and is out of place or has debris in it, it should be replaced as designed and debris should be removed to ensure proper flow of incoming water.

### 2.8.1.2 *Vegetation Management*

Inspection of vegetation management activities include inspecting the BAM system for evidence of dead and/or unhealthy plants, that the plant community is still according to approved plans, and that the vegetation has a manicured look. The below descriptions are intended to provide more detailed information on the specific action items for BAM vegetation management noted in the check list.

- VM1:** The vegetation in the BAM system should be inspected monthly for dead and/or unhealthy plants. If present, the affected plants should be removed and replaced. If a particular plant type appears to not do well in a particular location, e.g., multiple plant replacements at a particular location, observations should be made to attempt to determine the reason for failure. Examples could be too much/not enough sunlight, too much/not enough water, or excessive erosive forces. If the plant is doing well in other areas of the BAM system, observations of those locations should be made to see what is different from the problem location. New plant types from the appropriate plant lists included in this manual should be tried in the problem location until a successful variety is identified. The plants should also be inspected for evidence of pest infestations. Pest infestations should be treated using species specific natural control methods when possible, and chemical controls should be avoided.
- VM2:** The vegetation in the BAM system should be inspected monthly to ensure that the plant community composition is still according to approved plans. As-built plans that include relevant design details should be provided to the maintenance crew. Additionally, a list of the plants in the BAM system should be provided, including pictures of the plant at all stages of life (seedlings, juvenile, mature, dormant (if applicable)), as well as examples of healthy and not conditions. Signs of unacceptable water quality indicates that the system is not functioning as designed, along with unplanned growth of aquatic/wetland plants in the BAM area. Plants that are not part of the intended plant list, such as weeds, invasive exotic plants, and nuisance species, are to be removed. Weeding should be done by hand, not with a power trimmer, and the plant should be pulled from the base of the plant, making sure to remove as much of the root ball as possible. New plants should be installed according to the original plant list if sufficient vegetative cover is not achieved.
- VM3:** The vegetation in the BAM system should be inspected monthly to determine if the vegetation present has a manicured look, i.e., does it need to be pruned. Maintenance personnel are to prune, edge, weed, mow irrigate, and fertilize plants as needed to maintain

a well-manicured look. Fertilization should be minimized to the extent practical and done according to State and County rules when necessary. These practices are most frequently needed during the establishment period. Some grasses need cutting back during winter. Plants should be trimmed back if they are impeding pathways.

### 2.8.1.3 System Performance

Inspection of the BAM enhancement surface activities include inspecting the BAM system for evidence of standing water, debris, and/or sediment accumulation that may impact the performance of the BAM system. The below descriptions are intended to provide more detailed information on the specific action items for BAM system performance noted in the check list.

- SP1:** The BAM system should be inspected monthly for evidence of standing water. Presence of wetland species can also be used as an indicator of extended ponding and saturated soils. If there is standing water, it is likely that one of the system layers are not functioning properly or are clogged. This can be due to several factors including accumulation of excess debris that can clog the system, compaction of the media layers, or long-term accumulation of fines along the growth media and mulch interface. Initial steps to address this issue should include removal of accumulated debris and sediments. Additionally, scarifying the growth media surface can increase infiltration capacity. If these steps fail to remedy the problem, some of the layers may need to be replaced to restore full function. It is recommended to try and identify which layer needs replacing rather than replacing the entire system. To do this, perform double ring infiltrometer testing at each layer by digging down to the interface of each layer and performing a test. Prevention of future accumulation of debris and sediments may necessitate pretreatment.
- SP2:** The BAM system should be inspected monthly for evidence of debris and sediment accumulation. Debris and sediment accumulation should be removed using manual methods. Prevention of future accumulation of debris and sediments may necessitate pretreatment to prevent frequent clogging of media.

## 2.8.2 Water Quality Performance Monitoring Guidance for BAM Enhancement Systems without Underdrains

Understanding the true performance of BAM enhancement systems will require adequate monitoring to ensure proper characterization of the practice. Optional water quality monitoring guidance can be found in **Appendix 2C**.

### 2.8.3 Inspection Steps and Checklists for BAM Enhancement Systems with Underdrains

Operation of BAM enhancement systems requires adequate maintenance to ensure proper function. This includes frequent inspections to identify maintenance issues, performance monitoring, and general weeding/debris removal.

This section provides steps, a checklist, and a flow chart for maintenance personnel to use while inspecting BAM enhancement systems. The checklist can be found in **Appendix 2D**, and the flow chart can be found in **Appendix 2E**. A plan sheet for each site is to be included with every

inspection sheet and it is encouraged that the maintenance personnel mark up the plan sheet as needed. Inspection includes the system surface, vegetation, and overall system performance. To aid the inspector during the maintenance process and in completing the checklist, the necessary inspection and maintenance activities are described below.

### **2.8.3.1 BAM System Surface Activities**

Inspection of system surface activities includes inspecting the BAM system for evidence of erosion and if the inflow and overflow points are free of debris. The below descriptions are intended to provide more detailed information on the specific action items for BAM surface inspection noted in the check list.

- BS1:** BAM enhancement systems should have all their surface areas monthly for evidence of erosion. If there is evidence of erosion, such as rills or gullies or accumulation of sediments, the impacted areas should be restored and incorporation of erosion and sediment control products to protect against erosive forces should be considered. This can include stabilization practices such as rolled erosion control products, hard armoring, riprap, or the incorporation of additional vegetation to protect soils and slow the velocity of the incoming water.
- BS2:** BAM enhancement systems inflow and overflow points should be inspected monthly to determine if the inflow and overflow points are in working order. If riprap is used and is out of place or has debris in it, it should be replaced as designed and debris should be removed to ensure proper flow of incoming water. All underdrain pipes should be flushed and/or vacuumed once a year to ensure proper inflow and outflow of water.

### **2.8.3.2 Vegetation Management**

Inspection of vegetation management activities include inspecting the BAM system for evidence of dead and/or unhealthy plants, that the plant community is still according to approved plans, and that the vegetation has a manicured look. The below descriptions are intended to provide more detailed information on the specific action items for BAM vegetation management noted in the check list.

- VM1:** The vegetation in the BAM system should be inspected monthly for dead and/or unhealthy plants. If present, the affected plants should be removed and replaced. If a particular plant type appears to not do well in a particular location, e.g., multiple plant replacements at a particular location, observations should be made to attempt to determine the reason for failure. Examples could be too much/not enough sunlight, too much/not enough water, or excessive erosive forces. If the plant is doing well in other areas of the BAM system, observations of those locations should be made to see what is different from the problem location. New plant types from the appropriate plant lists included in this manual should be tried in the problem location until a successful variety is identified. The plants should also be inspected for evidence of pest infestations. Pest infestations should be treated using species specific natural control methods when possible, and chemical controls should be avoided.

- VM2:** The vegetation in the BAM system should be inspected monthly to ensure that the plant community composition is still according to approved plans. As-built plans that include relevant design details should be provided to the maintenance crew. Additionally, a list of the plants in the BAM system should be provided, including pictures of the plant at all stages of life (seedlings, juvenile, mature, dormant (if applicable)), as well as examples of healthy and not conditions. Signs of unacceptable water quality indicates that the system is not functioning as designed, along with unplanned growth of aquatic/wetland plants in the BAM area. Plants that are not part of the intended plant list, such as weeds, invasive exotic plants, and nuisance species, are to be removed. Weeding should be done by hand, not with a power trimmer, and the plant should be pulled from the base of the plant, making sure to remove as much of the root ball as possible. New plants should be installed according to the original plant list if sufficient vegetative cover is not achieved.
- VM3:** The vegetation in the BAM system should be inspected monthly to determine if the vegetation present has a manicured look, i.e., does it need to be pruned. Maintenance personnel are to prune, edge, weed, mow irrigate, and fertilize plants as needed to maintain a well-manicured look. Fertilization should be minimized to the extent practical and done according to State and County rules when necessary. These practices are most frequently needed during the establishment period. Some grasses need cutting back during winter. Plants should be trimmed back if they are impeding pathways.

### 2.8.3.3 System Performance

Inspection of the BAM enhancement surface activities include inspecting the BAM system for evidence of standing water, debris, and/or sediment accumulation that may impact the performance of the BAM system. The below descriptions are intended to provide more detailed information on the specific action items for BAM system performance noted in the check list.

- SP1:** The BAM system should be inspected monthly for evidence of standing water above the NWL. If there is standing water above the NWL for longer than expected, it is likely that one of the system layers are not functioning properly or are clogged. This can be due to several factors including accumulation of excess debris that can clog the system, compaction of the media layers, or long-term accumulation of fines along the growth media and mulch interface. Initial steps to address this issue should include removal of accumulated debris and sediments. Additionally, scarifying the growth media surface can increase infiltration capacity. All underdrain pipes in the system should be flushed and/or vacuumed once a year to prevent sediment buildup and clogging. If these steps fail to remedy the problem, some of the layers may need to be replaced to restore full function. It is recommended to try and identify which layer needs replacing rather than replacing the entire system. To do this, perform double ring infiltrometer testing at each layer by digging down to the interface of each layer and performing a test. Prevention of future accumulation of debris and sediments may necessitate pretreatment.
- SP2:** The BAM system should be inspected monthly for evidence of debris and sediment accumulation. Debris and sediment accumulation should be removed using manual methods and underdrain pipes should be flushed to prevent future accumulation and

clogging. Prevention of future accumulation of debris and sediments may necessitate pretreatment to prevent frequent clogging of media.

#### 2.8.4 Water Quality Performance Monitoring Guidance for BAM Enhancement Systems with Underdrains

Understanding the true performance of BAM enhancement systems will require adequate monitoring to ensure proper characterization of the practice. Optional water quality monitoring guidance can be found in **Appendix 2F**.

### 2.9 Design Calculations Example for Well-Draining Sandy Soils

This example calculation examines a scenario with well-draining sandy soils, which would be representative of the western portion of the county where there is a greater occurrence of well-draining sandy soils with deep water tables. For this example, it is assumed that a 3-acre pasture site located within the boundaries of the SFWMD is to be developed into a high-density commercial site. Soil types are hydrologic soils group (HSG) A. The calculations presented below demonstrate how to design a BAM system to achieve the required water quality treatment in the forebay treatment area. It is noted that the following example calculation is for projects within special basins, which can be found in FAC 62-330.

The first step is to determine the required treatment volume per the water management district (WMD) and the County criteria. As this practice is an infiltration based practice, the water quality benefit would be associated with the volume of water infiltrated. Since this example scenario is located within the SFWMD boundary, the SFWMD criteria for dry retention is the relevant water quality criteria for this project. A summary of pre- and post- development conditions are presented below followed by details of the BAM system design, the required treatment volume, and the final size of the system.

- Site conditions summary
  - Pre-development conditions
    - Land use: 3-acre site, pasture
    - Soil types: HSG A
  - Post-development conditions
    - Land use:
      - 2.4-acre site high density commercial
      - 0.6 acre will be open space (**20% open space requirement**)
    - Soil types: HSG A
    - Impervious areas:
      - Commercial area will be **60% impervious**
      - 1.8 acres will be impervious
- Proposed LID practice summary
  - Proposed BAM system is to have the following dimensions:
    - 88.6 feet in length

- 51.1 feet in width
    - 4 feet in depth
  - Proposed BAM system is to have the following media layers:
    - 2 inch coarse sand
    - 12 inch BAM
    - 6 inch top soil
    - Florida Friendly Landscaping
    - 4:1 (H:V) side slopes if fenced, 5:1 if unfenced
  - Since groundwater table and soils are not an issue at this site, no underdrain is proposed
- Determination of required treatment volume
  - As previously stated, the proposed system is a dry retention practice. Based on the SFWMD ERP handbook vol. 2 (SFWMD, 2016), the water quality treatment volume is 50% of either a) 1 inch of runoff from the developed site or b) 2.5 inches of runoff from the impervious area; whichever is greater.
    - a):  $\frac{3 \text{ ac} (1 \text{ in})}{12 \text{ in/ft}} = 0.25 \text{ ac} - \text{ft} \div 2 = 0.125 \text{ ac} - \text{ft}$
    - b):  $\frac{1.8 \text{ ac} (2.5 \text{ ac})}{12 \text{ in/ft}} = 0.375 \text{ ac} - \text{ft} \div 2 = 0.1875 \text{ ac} - \text{ft}$
    - Since the 2.5 inch of runoff produces the greater treatment volume, this is the value required by the SFWMD
  - Per the current state special basin criteria, as listed in FAC 62-330, water quality standard, an additional 50% treatment volume is required. This is calculated as:
    - $0.1875 \text{ ac} - \text{ft} * 1.5 = 0.281 \text{ ac} - \text{ft}$
    - Therefore, the total treatment volume required for this project is 0.281 acre-feet
- Based on the above water quality treatment volume determination, the BAM system must provide 0.281 acre-feet of storage. Sizing of the BAM system is an iterative process where an initial area is assumed and based on the standard section of the proposed system, a provided volume can be determined. This is achieved easiest using a spreadsheet so values can be quickly and easily changed until the treatment volume is achieved.
  - Specifically, each aggregate layer is multiplied by the depth, area, and porosity to determine the water volume provided
  - The ponding volume is determined using the methods presented in **Section 2-2**, above
  - Following this process, and assuming a rectangular geometry with 4:1 (H:V) slopes for the ponding volume and a total depth of 4 feet, a total area at top of bank of 0.12 acres was determined.
- Based on this, a BAM system with a 2 inch coarse sand layer, 12 inch BAM layer, 6 inch top soil layer, and 4:1 side slopes would need to be 0.12 acres to provide sufficient treatment for a 3 acre high intensity commercial site.

- It is noted that the example problem sizing of the BAM system is only for pollutant treatment purposes, not for flood control purposes. However, the BAM system will provide some flood control, resulting in a smaller pond needed for flood control elsewhere on the site.

## 2.10 Design Calculations Example for Poor-Draining / High Water Table Soils or Sensitive Groundwater Areas

This example calculation examines a scenario with poorly-drained sandy soils, which would be representative of the eastern portion of the county where there is a greater occurrence of poorly-drained sandy soils with shallow water tables. For this example, it is assumed that a 3-acre pasture site located within the boundaries of the SFWMD is to be developed into a high-density commercial site. Soil types are dual-hydrologic soils group (HSG) A/D. In scenarios where the soil type is a dual-hydrologic group, it is recommended to use the second letter for a more conservative estimate. The calculations presented below demonstrate how to design a BAM enhancement in high groundwater conditions to achieve the required water quality treatment. This example illustrates a wet detention pond with a side bank filter. Runoff must pass through the filter media and be collected in the perforated pipe before being discharged. It is noted that the following example calculation is for projects within special basins, which can be found in FAC 62-330.

The first step is to determine the required treatment volume per the water management district (WMD) and the County criteria. As this practice is a wet detention based practice, the water quality benefit would be associated with the volume of water that is captured and filtered through the BAM enhanced system. Since this example scenario is located within the SFWMD boundary, the SFWMD criteria for wet detention is the relevant water quality criteria for this project. A summary of pre- and post- development conditions are presented below followed by details of the BAM system design, the required treatment volume, and the final size of the system.

- Site conditions summary
  - Pre-development conditions
    - Land use: 3-acre site, pasture
    - Soil types: HSG A/D
  - Post-development conditions
    - Land use:
      - 2.4-acre site high density commercial
      - 0.6 acre will be open space (**20% open space requirement**)
    - Soil types: HSG A/D
    - Impervious areas:
      - Commercial area will be **60% impervious**
      - 1.8 acres will be impervious
- Proposed LID practice summary
  - Proposed BAM system is to have the following media layers:
    - 8 inch #57 stone



- 2 inch #89 stone
  - 2 inch coarse sand
  - 12 inch BAM
  - 6 inch coarse sand
  - Florida Friendly Landscaping
  - 4:1 (H:V) side slopes if fenced, 5:1 if unfenced
  - Since groundwater table and soils are not an appropriate for infiltration at this site, a wet detention pond with a side bank filter and perforated drain with a diameter of 6 inches is proposed to facilitate system recovery
- Determination of required treatment volume
  - As previously stated, the proposed system is a wet detention practice. Based on the SFWMD ERP handbook vol. 2 (SFWMD, 2016), the water quality treatment volume is either a) 1 inch of runoff or b) 2.5 inches of runoff from the impervious area; whichever is greater.
    - a):  $\frac{3 \text{ ac}(1 \text{ in})}{12 \text{ in/ft}} = 0.25 \text{ ac} - \text{ft}$
    - b): 2.5 inches over the impervious area:  $\frac{1.8 \text{ ac}(2.5 \text{ in})}{12 \text{ in/ft}} = 0.375 \text{ ac} - \text{ft}$
    - Since the 2.5 inches of runoff over the impervious area produces the greater treatment volume, this is the value required by the SFWMD
  - Per the current state special basin criteria, as listed in FAC 62-330, water quality standard, an additional 50% treatment volume is required. This is calculated as:
    - $0.375 \text{ ac} - \text{ft} * 1.5 = 0.5625 \text{ ac} - \text{ft}$
    - Therefore, the total treatment volume required for this project is 0.5625 acre-feet
- Based on the above water quality treatment volume determination, the BAM system must provide 0.5625 acre-feet of storage. Sizing of the BAM system is an iterative process where an initial area is assumed, and based on the standard section of the proposed system, a provided volume can be determined. This is achieved easiest using a spreadsheet so values can be quickly and easily changed until the treatment volume is achieved.
  - Specifically, each aggregate layer is multiplied by the depth, area, and porosity to determine the water volume provided
  - The ponding volume is determined using the methods presented in **Section 2-2**, above
  - Following this process, and assuming a rectangular geometry with 4:1 (H:V) slopes for the ponding volume and a 1 foot ponding area, a total area at top of bank of 0.325 acres was determined.
- Based on this, a BAM system with a 8 inch #57 stone layer, 2 inch #89 stone layer, 2 inch coarse sand layer, 12 inch BAM layer, 6 inch coarse sand layer, and 4:1 side slopes would need to be 0.325 acres to provide sufficient treatment for a 3 acre high intensity commercial site. For BAM media, the permeability rate is 0.83 ft/hr, per media manufacturer, the pond depth at NWL is 6 feet, and the pond treatment depth above NWL is calculated to be 2 feet.

The required filter area is calculated by multiplying the provided treatment volume by the safety factor of 2, and dividing by the filter media permeability and time to discharge.

- It is noted that the example problem sizing of the BAM enhancement is only for pollutant treatment purposes, not for flood control purposes. However, the volume provided by the treatment forebay area can count towards the required flood control volumes.
- Since this system has an underdrain, the capacity of the underdrain pipe must be checked to ensure that the pipe can convey the design flow rates. This can be readily calculated using a modified form of the Manning's Equation:

$$d_i = \left( \frac{1630 Q_p n}{\sqrt{S}} \right)^{\frac{3}{8}}$$

where:  $d_i$  = Inside pipe diameter (in)  
 $n$  = Manning's coefficient of roughness  
 $Q_p$  = Peak design discharge rate (cfs)  
 $S$  = Slope of the pipe (ft/ft)

If the pipe cannot convey the peak flow rate, additional head losses must be considered in the recovery time, or a larger size pipe must be used.

## REFERENCES

1. Minnesota Stormwater Manual (2022). Soil water storage properties.  
[https://stormwater.pca.state.mn.us/index.php/Soil\\_water\\_storage\\_properties](https://stormwater.pca.state.mn.us/index.php/Soil_water_storage_properties)
2. Woessner, W.W. and Poeter, E. P. (2022). Hydrogeologic Properties of Earth Materials and Principles of Groundwater Flow. ISBN: 978-1-7770541-2-0. <https://gw-project.org/books/hydrogeologic-properties-of-earth-materials-and-principles-of-groundwater-flow/>
3. SFWMD (2016). Environmental Resource Permit Applicant's Handbook Volume 2.  
[https://www.sfwmd.gov/sites/default/files/documents/swerp\\_applicants\\_handbook\\_vol\\_ii.pdf](https://www.sfwmd.gov/sites/default/files/documents/swerp_applicants_handbook_vol_ii.pdf)
4. SJRWMD (2018). Environmental Resource Permit Applicant's Handbook Volume 2.  
<https://www.sjrwmd.com/static/permitting/PIM-20180601.pdf>

## **APPENDIX 2A**

# **BAM without Underdrains Operation and Maintenance Checklist**

<b>Inspection and Maintenance Checklist for BAM without Underdrains</b>			
Facility Name and Address:			
Date of Inspection:			
Site Conditions:	Excellent <input type="checkbox"/>	Good <input type="checkbox"/>	Adequate <input type="checkbox"/> Poor <input type="checkbox"/>
Date of Last Rain Event:			
Inspection Frequency Type:	Monthly <input type="checkbox"/>	Quarterly <input type="checkbox"/>	Annual <input type="checkbox"/>
<b>Inspection Activities</b>			
Visual inspections are an integral part of system maintenance. Inspection includes monitoring for drainage, debris and sediment accumulation, vegetation health and coverage, and surface deterioration.			
Inspection Item	Checked (Y/N)	Maintenance Needed (Y/N)	Corrective Action/Comments
<b>BAM SURFACE (Frequency – Monthly)</b>			
BS1. Evidence of erosion (i.e., visible rills or gullies or sediment accumulation)			
BS2. Inflow and overflow points in working order			
<b>VEGETATION MANAGEMENT (Frequency – Quarterly)</b>			
VM1. Evidence of dead or unhealthy plants			
VM2. Is plant community composition still according to approved plans?			
VM3. Do plants appear well maintained/manicured			

<b>SYSTEM PERFORMANCE (Frequency – Monthly)</b>			
SP1. Evidence of standing water			
SP2. Debris and sediment accumulation			
<b>OVERALL CONDITION OF FACILITY</b>			
In accordance with approved design plans? (Y/N)			
Maintenance required as result of deficiencies detailed above? (Y/N)			
Date by which maintenance must be completed: (Y/N)			
<b>NOTES</b>			

CERTIFICATION SIGNATURE	
Company Name:	
Company email, address, and phone number:	
Name of Inspector:	
Inspector Signature:	

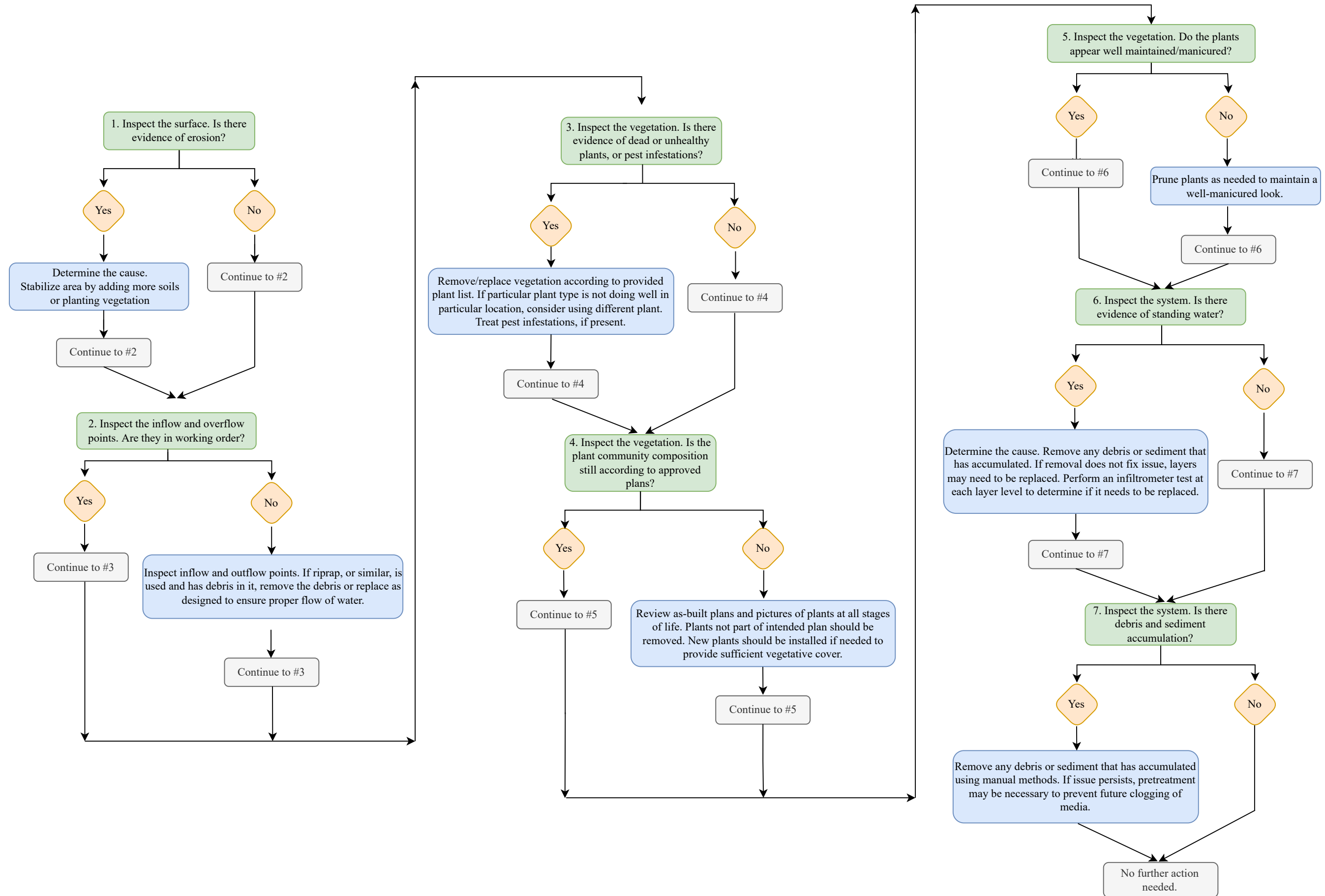
Note: Take a minimum of 5 representative photos of the BAM area, attach the photos to the form, and include any additional observations in the notes section prior to submission. Make sure to include pictures of any inflow/outflow points, the vegetation, and any other aspects of the BAM system.

## **APPENDIX 2B**

# **BAM without Underdrains Operation and Maintenance Flow Chart**



# BAM Systems without Underdrain Operation and Maintenance



## **APPENDIX 2C**

# **BAM without Underdrains Water Quality Performance Monitoring Guidance**

## Water Quality Performance Monitoring

To determine if the BAM system is performing as intended, water quality monitoring should be performed. This includes sampling water at key locations within the BAM system as well as accumulated sediment and debris removed as part of maintenance activities. To properly monitor this LID practice the pollutant flow path, removal mechanisms, and the downstream waterbody of interest needs to be identified. To aid in the design of a proper BAM system monitoring program, the general steps below can be followed. It is noted that the below sampling recommendations are relevant for a BAM system that is installed in a region with a deep groundwater table.

Define the treatment objective and the downstream waterbody of interest. Specifically, determine the water quality parameter(s) of interest and if the goal is to reduce loading to a surface waterbody or groundwater. This will dictate how the practice should be monitored.

- h. If the waterbody of interest is a surface water, then the bulk of the water quality benefit is associated with the volume reduction provided by the practice. Thus, monitoring should focus on characterization of the flow and parameter EMCs of water at the system locations specified below.
  - i. The system inflow
  - ii. The system overflow
- i. Additionally, nutrients and other pollutants can be removed from the system in the form of maintenance activities that are performed, e.g., removal of vegetation, removal of sediments, removal of organic debris. Thus, the mass of pollutants associated with the following should also be characterized.
  - i. Accumulated sediments and organic debris
  - ii. Removed vegetation
- j. If the waterbody of interest is the groundwater, then, in addition to monitoring the inflow to the BAM system, sampling of the water entering the ground should also be performed.
  - i. To sample water as it enters the ground, a lysimeter is to be installed in the BAM system so that it can be sampled. Guidance on how to construct and install a lysimeter can be found here: <https://edis.ifas.ufl.edu/publication/AE554>. The sizing of the lysimeter should be based on the desired sample volume so that the lysimeter can hold the anticipated volume.
- k. Flow monitoring should be performed using an area-velocity probe, or other equipment appropriate for continuous estimation of flow, such as the ISCO 2150 area velocity probe.

- l. Stormwater sampling should be performed using auto-sampler equipment capable of collecting time- or flow-weighted composite samples, including but not limited to ISCO 6712 autosamplers. It is noted that, if possible, refrigerated autosamplers are preferred as they are able to preserve samples quicker than field personnel can collect samples.
- m. Storm events that are typical of Central Florida weather are to be sampled to evaluate typical performance of BAM enhancement systems. A rain gauge is to be installed onsite to measure rainfall at the site.
- n. System performance can be determined as the mass that is retained or removed from the BAM system. This is determined as the difference in the mass entering the system and the mass leaving the system.
  - i. The mass entering the system can be determined based on the flow and constituent EMC. It is noted that while autosamplers are effective at characterizing the fine particulates and dissolved pollutants in stormwater, they are not effective at capturing coarser sediments and organic material. As such, when such materials are removed from BAM enhancement systems as part of maintenance activities, the mass of constituent associated with these activities must be considered as part of the loading to the system as well as loading removed from the system.
  - ii. One mass output is the mass leaving as surface runoff. This can be determined based on the overflow volume and constituent EMC.
  - iii. Another mass output is the mass of pollutants associated with removal of debris, sediments, or vegetation due to maintenance activities performed on the BAM system. This can be determined based on the mass of material, constituent content, and moisture content of materials removed.
  - iv. The mass leaving to the groundwater can be determined based on the difference in inflow and overflow volume, and the constituent EMC as measured from the lysimeter.
  - v. The performance of the system can be determined based on the difference between the mass entering the BAM system and the mass discharged to the downstream waterbody of interest.

## **APPENDIX 2D**

# **BAM with Underdrains Operation and Maintenance Checklist**

<b>Inspection and Maintenance Checklist for BAM with Underdrains</b>			
Facility Name and Address:			
Date of Inspection:			
Site Conditions:	Excellent <input type="checkbox"/>	Good <input type="checkbox"/>	Adequate <input type="checkbox"/> Poor <input type="checkbox"/>
Date of Last Rain Event:			
Inspection Frequency Type:	Monthly <input type="checkbox"/>	Quarterly <input type="checkbox"/>	Annual <input type="checkbox"/>
<b>Inspection Activities</b>			
Visual inspections are an integral part of system maintenance. Inspection includes monitoring for drainage, debris and sediment accumulation, vegetation health and coverage, and surface deterioration.			
Inspection Item	Checked (Y/N)	Maintenance Needed (Y/N)	Corrective Action/Comments
<b>BAM SURFACE (Frequency – Monthly)</b>			
BS1. Evidence of erosion (i.e., visible rills or gullies or sediment accumulation)			
BS2. Inflow and overflow points in working order			
<b>VEGETATION MANAGEMENT (Frequency – Quarterly)</b>			
VM1. Evidence of dead or unhealthy plants			
VM2. Is plant community composition still according to approved plans?			
VM3. Do plants appear well maintained/manicured			

<b>SYSTEM PERFORMANCE (Frequency – Monthly)</b>			
SP1. Evidence of standing water above NWL for longer than _____ expected, flushing/vacuuming pipes			
SP2. Debris and sediment accumulation			
<b>OVERALL CONDITION OF FACILITY</b>			
In accordance with approved design plans? (Y/N)			
Maintenance required as result of deficiencies detailed above? (Y/N)			
Date by which maintenance must be completed: (Y/N)			
<b>NOTES</b>			

CERTIFICATION SIGNATURE	
Company Name:	
Company email, address, and phone number:	
Name of Inspector:	
Inspector Signature:	

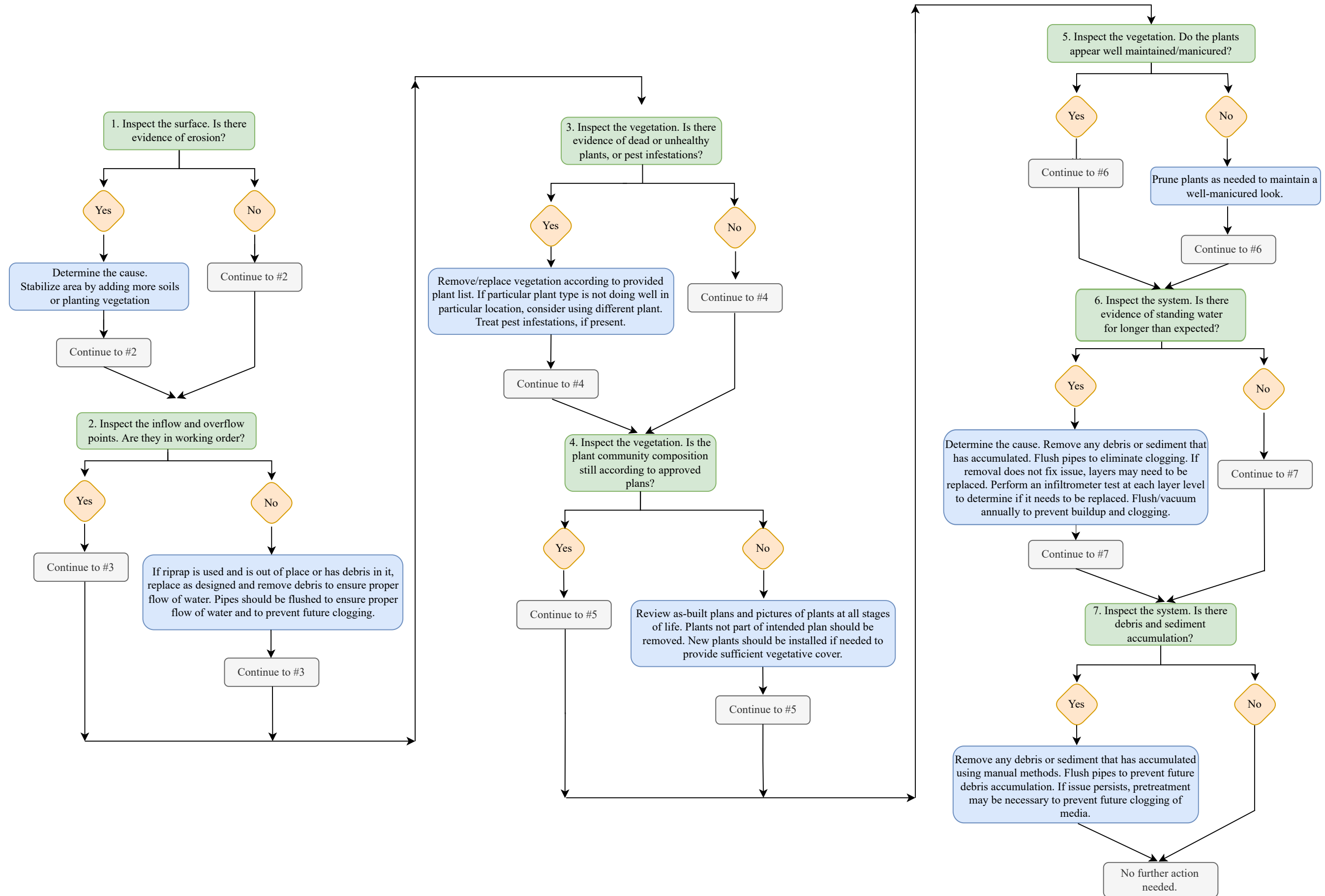
Note: Take a minimum of 5 representative photos of the BAM area, attach the photos to the form, and include any additional observations in the notes section prior to submission. Make sure to include pictures of any inflow/outflow points, the vegetation, and any other aspects of the BAM system.



## **APPENDIX 2E**

# **BAM with Underdrains Operation and Maintenance Flow Chart**

# BAM Systems with Underdrain Operation and Maintenance



## **APPENDIX 2F**

# **BAM with Underdrains Water Quality Performance Monitoring Guidance**

## Water Quality Performance Monitoring

This includes sampling water at key locations within the BAM system as well as accumulated sediment and debris removed as part of maintenance activities. To properly monitor this LID practice the pollutant flow path, removal mechanisms, and the downstream waterbody of interest needs to be identified. To aid in the design of a proper BAM system monitoring program, the general steps below can be followed. It is noted that the below sampling recommendations are relevant for a BAM system that is installed in a region with a seasonal high groundwater table.

Define the treatment objective and the downstream waterbody of interest. Specifically, determine the water quality parameter(s) of interest and if the goal is to reduce loading to a surface waterbody or groundwater. This will dictate how the practice should be monitored.

- a. If the waterbody of interest is a surface water, then the bulk of the water quality benefit is associated with the volume reduction provided by the practice. Thus, monitoring should focus on characterization of the flow and parameter EMCs of water at the system locations specified below.
  - i. The system inflow
  - ii. The system overflow
- b. Additionally, nutrients and other pollutants can be removed from the system in the form of maintenance activities that are performed, e.g., removal of vegetation, removal of sediments, removal of organic debris. Thus, the mass of pollutants associated with the following should also be characterized.
  - i. Accumulated sediments and organic debris
  - ii. Removed vegetation
- c. If the waterbody of interest is the groundwater, then, in addition to monitoring the inflow to the BAM system, sampling of the water entering the ground should also be performed.
  - i. To sample water as it enters the ground, a lysimeter is to be installed in the BAM system so that it can be sampled. Guidance on how to construct and install a lysimeter can be found here: <https://edis.ifas.ufl.edu/publication/AE554>. The sizing of the lysimeter should be based on the desired sample volume so that the lysimeter can hold the anticipated volume.
- d. Flow monitoring should be performed using an area-velocity probe, or other equipment appropriate for continuous estimation of flow, such as the ISCO 2150 area velocity probe.

- e. Stormwater sampling should be performed using auto-sampler equipment capable of collecting time- or flow-weighted composite samples, including but not limited to ISCO 6712 autosamplers. It is noted that, if possible, refrigerated autosamplers are preferred as they are able to preserve samples quicker than field personnel can collect samples.
- f. Storm events that are typical of Central Florida weather are to be sampled to evaluate typical performance of BAM enhancement systems. A rain gauge is to be installed onsite to measure rainfall at the site.
- g. System performance can be determined as the mass that is retained or removed from the BAM system. This is determined as the difference in the mass entering the system and the mass leaving the system.
  - i. The mass entering the system can be determined based on the flow and constituent EMC. It is noted that while autosamplers are effective at characterizing the fine particulates and dissolved pollutants in stormwater, they are not effective at capturing coarser sediments and organic material. As such, when such materials are removed from BAM enhancement systems as part of maintenance activities, the mass of constituent associated with these activities must be considered as part of the loading to the system as well as loading removed from the system.
  - ii. One mass output is the mass leaving as surface runoff. This can be determined based on the overflow volume and constituent EMC.
  - iii. Another mass output is the mass of pollutants associated with removal of debris, sediments, or vegetation due to maintenance activities performed on the BAM system. This can be determined based on the mass of material, constituent content, and moisture content of materials removed.
  - iv. The mass leaving to the groundwater can be determined based on the difference in inflow and overflow volume, and the constituent EMC as measured from the lysimeter.
  - v. The performance of the system can be determined based on the difference between the mass entering the BAM system and the mass discharged to the downstream waterbody of interest.

# **ATTACHMENT 3**

## **Tree Box Filters**



engineers | scientists | innovators



**STORMWATER LOW IMPACT  
DEVELOPMENT MANUAL, VOLUME 2**

**ATTACHMENT 3**

**TREE BOX FILTER**

*Prepared for*

**Orange County Planning Division**  
201 S. Rosalind Ave., 2<sup>nd</sup> Floor  
Orlando, FL 32802

**Orange County Public Works**  
4200 S John Young Parkway  
Orlando, FL 32839

**Orange County Environmental Protection Division**  
3165 McCrory Place, Suite 200  
Orlando, FL 32803

*Prepared by*

Geosyntec Consultants, Inc.  
3504 Lake Lynda Drive, Suite 155  
Orlando, FL 32817

Project Number: FW8213

December 2023

## TABLE OF CONTENTS

3.	BACKGROUND .....	3-1
3.1	Design Features of Typical System.....	3-1
3.2	Design Guidance and Criteria .....	3-2
3.3	Site Suitability .....	3-4
3.4	Pollutant Removal Efficiencies .....	3-4
3.5	Regulatory and Permitting Considerations.....	3-4
3.6	Construction Considerations .....	3-5
3.7	Design Details and Specifications .....	3-5
3.8	Inspection, Maintenance, and Monitoring.....	3-7
3.8.1	Inspection Steps and Checklist for Tree Box Filter Systems with Underdrains ... .....	3-8
3.8.2	Water Quality Performance Monitoring Guidance for Tree Box Filter Systems with Underdrains .....	3-10
3.9	Design Calculations Example for Tree Box Filter Systems.....	3-10

## LIST OF TABLES

Table 3-1.	Porosity of Materials used in Tree Box Filter Areas.....	3-2
------------	--	-----

## LIST OF FIGURES

Figure 3-1:	Contained Tree Box Filter with Underdrain Details .....	3-6
Figure 3-2:	Tree Box Filter System in an Urban Landscape Setting.....	3-7



## **LIST OF APPENDICIES**

- Appendix 3A: Tree Box Filter with Underdrains Operation and Maintenance Checklist
- Appendix 3B: Tree Box Filter with Underdrains Operation and Maintenance Flow Chart
- Appendix 3C: Tree Box Filter with Underdrains Water Quality Monitoring Guidance

## ACRONYMS AND ABBREVIATIONS

BAM	Biosorption Activated Media
BMAP	Basin Management Action Plan
BMP	Best Management Practice
CEC	Cation Exchange Capacity
DCIA	Directly Connected Impervious Area
DEM	Digital Elevation Model
EMC	Event Mean Concentration
EPA	Environmental Protection Agency
ERP	Environmental Resource Permit
FAC	Florida Administrative Code
FDEP	Florida Department of Environmental Protection
GSI	Green Stormwater Infrastructure
H&H	Hydrologic and Hydraulic Modeling
ICPR4	Interconnected Channel and Pond Routing Model
LID	Low Impact Development
MS4	Municipal Separate Storm Sewer System
N <sub>2</sub>	Nitrogen Gas
NH <sub>3</sub>	Ammonia
NO <sub>2</sub>	Nitrite
NO <sub>3</sub>	Nitrate
NOAA	National Oceanic and Atmospheric Administration
NPDES	National Pollutant Discharge Elimination System
NWL	Normal Water Level
OFS	Outstanding Florida Springs
OFW	Outstanding Florida Waters
PFA	Primary Focus Area
RAP	Reasonable Assurance Plan
SFWMD	South Florida Water Management District
SJRWMD	St. Johns River Water Management District
SWMM	Storm Water Management Model

SWMP	Stormwater Management Program
Tc	Time of Concentration
TMDL	Total Maximum Daily Load
TN	Total Nitrogen
TP	Total Phosphorus
UF/IFAS	University of Florida/Institute of Food and Agricultural Sciences
VBS	Vegetated Buffer Strips
WERF	Water Environment Research Foundation
WMD	Water Management District

### 3. BACKGROUND

This attachment provides detailed information on tree box filter design. Design features of typical systems as well as design guidance and criteria are presented and discussed. Additionally, site suitability, pollutant removal efficiencies, regulatory and permitting considerations, construction considerations, and design details and specifications are presented. Finally, an example problem is presented to demonstrate design calculations for contained tree box filters with an underdrain which can be used in areas with poor draining soils/elevated water tables and areas with well draining soils/deep water tables.

#### 3.1 Design Features of Typical System

Tree box filter systems can be designed as a detention system where they contain an underdrain to collect water that has been filtered through system aggregate layers including a BAM layer. If added, the BAM layer can provide extra nutrient removal, but it is not required in areas with a deep groundwater table. However, a few distinguishable features include being smaller scale, the use of high permeability layers to increase water storage, and the use of vegetation, specifically trees or shrubs. They are usually located upstream of a standard curb inlet with a sediment sump and can be used in areas where infiltration is not possible, such as areas with clay soils. Tree box filters discussed in this manual are designed as a contained system with an underdrain. These systems typically have the following layers as a minimum, from system bottom to top:

- 8 inches (minimum) of #57 stone,
- 2 inches (minimum) of #89 stone,
- 2 inches (minimum) of coarse,
- 1 foot (minimum) of BAM,
- 6 inches (minimum) of growth media, and
- 3 inches (minimum) of mulch.

The above are examples of stone gradations that can be used. However, other stone gradations can also be used, but they need to be selected such that the pore sizes of the base material are not sufficiently large to allow the top layer to fill in voids. Some mixing at interface, interstitial mixing, is expected but a subsequent layer should be able to be built up. This bridging should eliminate need for filter fabrics since they are prone to clogging. Many nutrient removal practices encourage growth of biofilm for the uptake/removal mechanism. While performing an inherent beneficial process, if excess biofilm concentrates along filter fabric, it will choke out the pores resulting in a significant reduction in permeability and potentially clogging.

An underdrain, minimum 6 inch diameter perforated pipe, should be installed to collect water that percolates through the system and direct the collected water to the existing drainage system. A contained tree box system should be sized to provide a sufficient root zone for the mature tree conditions, based on recommendations from a certified arborist. Florida native trees or shrubs appropriate for the expected conditions, i.e., water depth/duration, amount of light, etc. are to be planted in the tree box filter system. Refer to **Appendix A** of the accompanying Volume 1 of this

LID manual for plant lists for the different conditions found within the County as well as guidance on choosing trees based on soil volume available.

### 3.2 Design Guidance and Criteria

Tree box filter systems are typically used to help reduce the volume of runoff leaving a site and provide filtration and sorption of pollutants by the plants and different media layers. While these systems can alleviate flooding, they will often by themselves not have the capacity to provide the entirety of site flood storage requirements. While these systems are typically incorporated into a design to meet a water quality criteria, the volume provided can be used to off-set flood control volume requirements. Based on this, sizing of these systems will typically be based on the required water quality treatment that must be provided. This sets forth a presumptive criteria that water quality targets are being met if this level treatment is provided. The design example presented below demonstrates the calculation methodology necessary to determine the appropriate water quality treatment volume.

Tree box filter systems are composed of specific materials that each serve a specific function within the system. Rock aggregate layers provide water storage, facilitate drainage, provide bridging layers to minimize movement of different materials to different layers, and evenly distribute water. The coarse sand layer performs similar functions as the rock aggregate layers, providing some water storage, bridging, and facilitating drainage. The mulch layer is intended to hold moisture in the system and minimize weed growth. The water storage associated with these layers can be determined by multiplying the material depth by the area and the porosity (**Table 3-1**).

**Table 3-1. Porosity of Materials used in Tree Box Filter Areas**

Material	Recommended Porosity Value	Reference
#89 Stone	25%	BMPTrains, 2020, v4.3.2
#57 Stone	21%	BMPTrains, 2020, v4.3.2
Coarse Sand	18%	Woessner & Poeter, 2020
BAM	20%	BMPTrains, 2020, v4.3.2
Mulch	70%	Sustainable Technologies, 2022
Growth Media (Sandy Loam)	14%	Minnesota Stormwater Manual, 2022

The ponding volume on top of the mulch layer can be determined using the equation below:

$$(A_1 \times D) + \left( (A_2 - A_1) \times D \times \frac{1}{2} \right) = V$$

Where:

$A_1$  = Area of the bottom slice of the ponding depth (ft<sup>2</sup>)

$A_2$  = Area of the top slice of the ponding depth (ft<sup>2</sup>)

$D$  = Ponding depth (ft)

$V$  = Volume of the ponding area (ft<sup>3</sup>)

Florida Friendly Landscaping should be leveraged and appropriate plants chosen based on the expected conditions. Additionally, consideration for the mature plant size should be considered when selecting plants. If the practice used is not going to provide sufficient root zone and soil volume needed for the mature plant, it is recommended to use something smaller and more appropriate. The plant lists supplied in **Appendix A** of the accompanying Volume 1 of this LID manual should be referred to for guidance on plant selection as well as guidance on choosing trees based on soil volume available.

Finally, some additional considerations are related to how water enters or leaves these systems. Inflow points should be protected using either a hard or soft armoring approach, depending on the anticipated flow rates and velocities. The State of Florida Erosion and Sediment Control Designer and Reviewer Manual (July 2013) provides guidance on acceptable velocities for different armoring practices. Similarly, overflow from the tree box filter system should be protected. An internal piped overflow, minimum of 6 inch diameter, could also be used. Tree box filters in areas that incorporate an underdrain into the design must ensure that sufficient underdrains be provided to drain the treatment volume within 72 hours (SFWMD, 2016; SJRWMD, 2018). This can be checked using a modified version of the Manning's Equation:

$$d_i = \left( \frac{1630 \times Q_p \times n}{\sqrt{S}} \right)^{3/8}$$

Where:

$d_i$  = Inside pipe diameter (in)

$n$  = Manning's coefficient of roughness

$Q_p$  = Peak discharge rate (cfs)

$S$  = Slope of pipe (ft/ft)

### 3.3 Site Suitability

Tree box filter systems should be strategically placed based on site conditions. Tree box filter systems are often located upstream of a standard curb inlet with a sediment sump. They can be used in areas where infiltration is not possible, such as in areas with clay soils, high groundwater tables, or areas with highly contaminated runoff. Additionally, tree box filter system design should incorporate an BAM layer for systems that have less than 3 feet of separation between the SHGWT and the system bottom to provide additional nutrient removal. All tree box filter systems will have a 6 inch diameter perforated underdrain, as it is a contained system.

As tree box filter systems are vegetation based practices, it is important to consider sun requirements as well as moisture conditions. The vegetation guidance provided in **Appendix A** of the accompanying Volume 1 of this LID manual should be referenced for guidance on plant selection as well as guidance on choosing trees based on soil volume available. The site should also account for the necessary soil volume and root space needed for the planned vegetation.

### 3.4 Pollutant Removal Efficiencies

The pollutant removal efficiency for tree box filter systems is based on the removal mechanisms of this practice. To determine the water quality benefit, estimate the average annual volume of water to enter the system, multiply by the appropriate event mean concentration (EMC), and then multiply by the removal efficiency of the pollution control media used. The average annual volume of water can be estimated by leveraging continuous simulation modeling or the methods of Harper and Baker (2007). Additionally, there are models and calculation tools that are based on the Harper and Baker (2007) method, such as the BMP Trains model, which can be used to estimate the water quality benefit of implementing tree box filter systems.

### 3.5 Regulatory and Permitting Considerations

Applicable criteria for the governing water management district are to be applied on a site by site basis. It is anticipated that tree box filter projects will require an Environmental Resource Permit (ERP) from the corresponding water management district (SFWMD, 2016; SJRWMD, 2018). For a project to qualify for an ERP it must be demonstrated that the proposed project will not result in upstream flooding or increases in peak stage, or not result in increases in peak discharge rates from the site, as well as meet water quality treatment requirements. It is noted that stormwater treatment performance standards vary depending on a number of site factors and are summarized as follows:

- If the proposed system discharges directly/indirectly to surface waters, it falls under the MS4 and NPDES rules,
- If the proposed system discharges directly to an Outstanding Florida Waterbody (OFW) or Outstanding Florida Springs (OFS), it falls under the FDEP OFW and OFS rule,
- If the proposed system is within waterbodies with TMDLs, it falls under the EPA rule which delegates the enforcing authority to FDEP, and

- If the proposed system is within watersheds that are on the verified impaired waterbodies list, sensitive groundwater areas, or waterbodies with BMAPS, 4b, or 4e plans, it falls under the FDEP rule.

The specific water quality treatment volume required varies depending on the criteria listed above. Additionally, for basins that do not currently require that additional 50% treatment volume, this manual requires the criteria be provided in all basins in Orange County, in addition to the relevant water management district requirements. This requirement may be affected by the pending statewide stormwater rule and should be evaluated after adoption of the rule, as this manual was started prior to the adoption of the statewide stormwater rule.

### 3.6 Construction Considerations

The following construction considerations should be considered when building a tree box filter system:

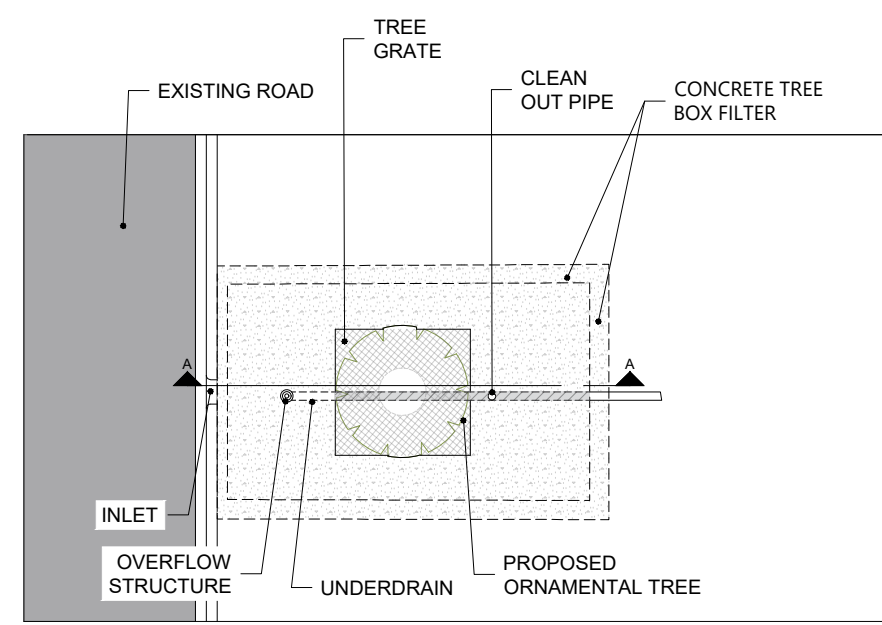
- Utilities should be contacted prior to digging to ensure it is clear to dig, otherwise relocation of the utilities will be necessary. The area to be excavated should be determined based on calculations done to meet nutrient removal needs.
  - No utility or other infrastructure shall be placed in the location of the LID structure that would interfere with the function or maintenance of the structure.
- Every effort should be made to minimize compaction of soils where the tree box filter system is proposed.
- A sufficient staging area should be provided where:
  - Plants can get sufficient sunlight and be easily watered to keep them alive prior to planting, and
  - Growth media, pollution control media, and rock aggregates can be stored without risk of contamination or mixing with site soils.
- Appropriate erosion and sediment control practices be incorporated to minimize site erosion and sediment loss.
- The size of the tree box filter should take into account the anticipated size of the mature plant.
- Plants that may excel in tree box filters include bald cypress, red maple, river birch, dahoon holly, fringetree, dwarf fakahatchee grass, lizards tail, yellow canna, and iris.

### 3.7 Design Details and Specifications

As part of this effort, design details and general specifications were developed. **Figure 3-1** shows the relevant design details for tree box filter systems with an underdrain. The design with the underdrain should be completely encased with concrete. General specifications are also included on each detail.

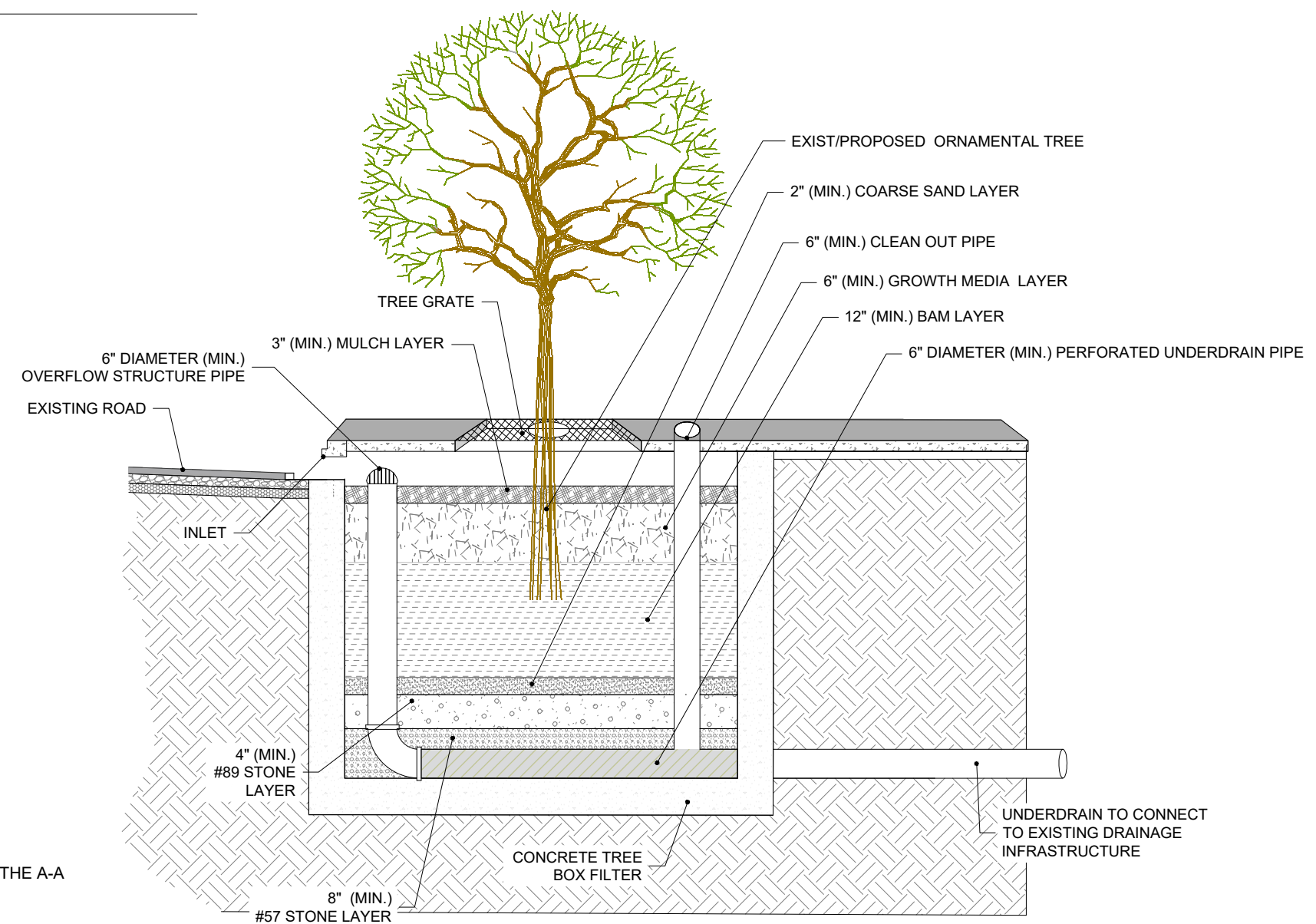


**PLAN**  
**TREE BOX FILTER**  
 (NOTE)  
 N.T.S.



- NOTES:**
1. CONTACT UTILITY COMPANY AND ENSURE UTILITY LINES ARE PROPERLY LOCATED PRIOR TO DIGGING OR TRENCHING.
  2. THE GROWTH MEDIA IS INTENDED TO PROMOTE HEALTHY PLANT GROWTH. GROWTH MEDIA SHALL BE A MINIMUM OF 6 INCHES IN DEPTH AND SHALL BE COMPOSED OF 50% COARSE SAND (ASTM 33), 25% TOPSOIL (LESS THAN 5% FINES PASSING #200 SIEVE), AND ORGANIC COMPOST (LEAF AND MULCH MIX).
  3. THE BAM LAYER IS INTENDED TO PROVIDE TN AND TP REMOVAL FROM STORMWATER AS IT PASSES THROUGH THE LAYERS AND GETS COLLECTED BY THE UNDERDRAIN.
  4. THE COARSE SAND LAYER IS INTENDED TO ACT AS A SUPPORT LAYER FOR THE BAM AND PROVIDE A BRIDGING LAYER TO PREVENT THE MIGRATION OF BAM MEDIA FROM ENTERING THE STONE RESERVOIR LAYERS BELOW. THE COARSE SAND SHOULD BE WASHED AND CONSISTENT WITH ASTM C-33. SAND SHALL BE FREE FROM OBJECTIONAL WEEDS, LITTER, SODS, STIFF CLAY, STONES, ROOTS, TRASH, HERBICIDES, TOXIC SUBSTANCES, OR ANY OTHER CHEMICAL THAT MAY BE HARMFUL TO THE ENVIRONMENT.
  5. AS THESE ARE SMALLER SCALE PRACTICES, IT IS RECOMMENDED TO PROVIDE A SYSTEM AS LARGE AS THE AVAILABLE SPACE WILL ALLOW, AS WATER QUALITY TREATMENT IS BASED ON THE AMOUNT OF WATER CAPTURED AND TREATED.
  6. THE CONCRETE TREE BOX FILTER SYSTEM SHOULD BE SUFFICIENTLY SIZED TO PROVIDE SUFFICIENT ROOT ZONE FOR THE MATURE TREE CONDITIONS BASED ON RECOMMENDATIONS FROM A CERTIFIED ARBORIST.
  7. THE UNDERDRAIN PIPE IS TO HAVE A MINIMUM PIPE DIAMETER OF 6 INCHES AND CONNECT TO DOWNSTREAM EXISTING DRAINAGE INFRASTRUCTURE TO FACILITATE DRAINAGE.

**SECTION**  
**TREE BOX FILTER**  
 (NOTE)  
 N.T.S.

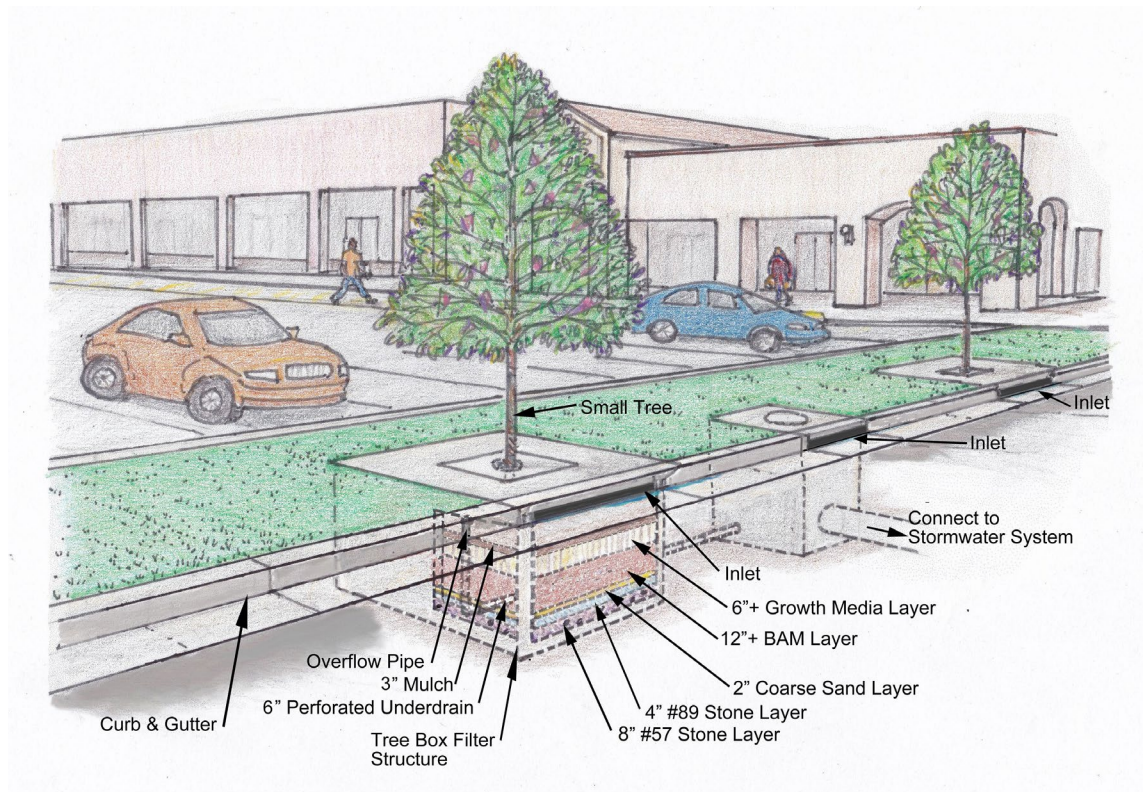


NOTE:  
 THIS SECTION REPRESENTS THE A-A  
 CROSS SECTION

<b>TREE BOX FILTER</b>  LID MANUAL DETAILS ORANGE COUNTY; FLORIDA	
<b>FIGURE</b> <b>3-1</b>	

### 3.8 Artist Renderings

Presented below is an artist rendering of how this practice may look incorporated into the urban landscape (**Figure 3-2**).



**Figure 3-2: Tree Box Filter System in an Urban Landscape Setting (Alliance Design & Construction, Inc.)**

### 3.9 Inspection, Maintenance, and Monitoring

Operation of tree box filter systems requires adequate maintenance to ensure proper function. This includes frequent inspections to identify maintenance issues, performance monitoring, and general weeding/debris removal. This attachment provides detailed information on the operation and maintenance required to ensure proper function of tree box filter systems. This attachment also includes an inspection and maintenance checklist that goes over site conditions, various inspection items, and allows maintenance personnel to note if maintenance is needed and what corrective actions are recommended (**Appendix 3A**). A flow chart is included to be used in tandem with the checklist, as it provides step by step action items to guide the maintenance personnel through the task (**Appendix 3B**). The numbered items on the flow chart correspond to the numbered items in the checklist. Additionally, optional monitoring guidance is provided in **Appendix 3C**.

The maintenance personnel are required to take a minimum of five photographs as well as notes describing the conditions of the tree box filter area. It is noted that five baseline photos should be

taken of the tree box filter system after construction is complete. Guidance on where the photos should be taken can be found at the end of **Appendix 3A** and **3D**. The notes should elaborate on any of the topics listed in the checklist but can also cover other observations made or actions taken that the maintenance personnel deems important. The maintenance checklists are required to be submitted annually to the County at an agreed upon date to ensure that the tree box filter system is being regularly maintained. Every 5 years, a professional engineer must check the system to ensure that it is functioning as designed and sign off on its performance. An alternative maintenance plan and/or schedule may be used with approval from the County engineer.

### 3.9.1 Inspection Steps and Checklist for Tree Box Filter Systems with Underdrains

Operation of tree box filter systems requires adequate maintenance to ensure proper function. This includes frequent inspections to identify maintenance issues, performance monitoring, and general weeding/debris removal.

This section provides steps, a checklist, and a flow chart for maintenance personnel to use while inspecting tree box filter systems. The checklist can be found in **Appendix 3A** and the flow chart can be found in **Appendix 3B**. A plan sheet for each site is to be included with every inspection sheet and it is encouraged that the maintenance personnel mark up the plan sheet as needed. Inspection includes the system surface, vegetation, and overall system performance. To aid the inspector during the maintenance process and in completing the checklist, the necessary inspection and maintenance activities are described below.

#### 3.9.1.1 Tree Box Filter System Surface Activities

Inspection of system surface activities includes inspecting the tree box filter system for evidence of erosion, determining if the mulch layer is in place, and if the inflow and overflow points are free of debris. The below descriptions are intended to provide more detailed information on the specific action items for tree box filter surface inspection noted in the check list.

- BS1:** Tree box filter systems should have all their surface areas inspected monthly for evidence of erosion. If there is evidence of erosion, such as rills or accumulation of sediments, the impacted areas should be restored and incorporation of erosion and sediment control products to protect against erosive forces should be considered. This can include stabilization practices such as rolled erosion control products, hard armoring, or the incorporation of additional vegetation to protect soils and slow the velocity of the incoming water.
- BS2:** Tree box filter systems mulch layer should be inspected monthly to determine if the mulch layer is still in place. If mulch has washed away, more mulch needs to be added until the desired depth (3 inches) is achieved. Mulch should be applied and raked to ensure even coverage. It is noted that mulch should be replaced in late winter before new growth sprouts. If mulch continues to get washed out, this could be indicative of a design issue that is failing to dissipate the velocity of water entering the system. Should this happen, it is recommended to examine how the system performs during a rainfall event to see how

water is entering the system and where some additional stabilization practices should be implemented to slow the velocity of the incoming water.

- BS3:** Tree box filter systems inflow and overflow points should be inspected monthly to determine if the inflow and overflow points are in working order. All underdrain pipes should be flushed and/or vacuumed once a year to ensure proper inflow and outflow of water.

### 3.9.1.2 *Vegetation Management*

Inspection of vegetation management activities include inspecting the tree box filter system for evidence of dead and/or unhealthy plants, that the plant community is still according to approved plans, and that the vegetation has a manicured look. The below descriptions are intended to provide more detailed information on the specific action items for tree box filter vegetation management noted in the check list.

- VM1:** The vegetation in the tree box filter system should be inspected monthly for dead and/or unhealthy plants. If present, the affected plants should be removed and replaced. If a particular plant type appears to not do well in a particular location, e.g., multiple plant replacements at a particular location, observations should be made to attempt to determine the reason for failure. Examples could be too much/not enough sunlight, too much/not enough water, or excessive erosive forces. If the plant is doing well in other areas of the tree box filter system, observations of those locations should be made to see what is different from the problem location. New plant types from the appropriate plant lists included in this manual should be tried in the problem location until a successful variety is identified. The plants should also be inspected for evidence of pest infestations. Pest infestations should be treated using species specific natural control methods when possible, and chemical controls should be avoided.
- VM2:** The vegetation in the tree box filter system should be inspected monthly to ensure that the plant community composition is still according to approved plans. As-built plans that include relevant design details should be provided to the maintenance crew. Additionally, a list of the plants in the tree box filter system should be provided, including pictures of the plant at all stages of life (seedlings, juvenile, mature, dormant (if applicable)), as well as examples of healthy and not conditions. Signs of unacceptable water quality indicates that the system is not functioning as designed, along with unplanned growth of aquatic/wetland plants in the tree box filter area. Plants that are not part of the intended plant list, such as weeds, invasive exotic plants, and nuisance species, are to be removed. Weeding should be done by hand, not with a power trimmer, and the plant should be pulled from the base of the plant, making sure to remove as much of the root ball as possible.
- VM3:** The vegetation in the tree box filter system should be inspected monthly to determine if the vegetation present has a manicured look, i.e., does it need to be pruned. Maintenance personnel are to prune, edge, weed, mow irrigate, and fertilize plants as needed to maintain a well-manicured look. Fertilization should be minimized to the extent practical and done according to State and County rules when necessary. These practices are most frequently

needed during the establishment period. Some grasses need cutting back during winter. Plants should be trimmed back if they are impeding pathways.

### **3.9.1.3 System Performance**

Inspection of the tree box filter surface activities include inspecting the tree box filter system for evidence of standing water, debris, and/or sediment accumulation that may impact the performance of the tree box filter system. The below descriptions are intended to provide more detailed information on the specific action items for tree box filter system performance noted in the check list.

- SP1:** The tree box filter system should be inspected monthly for evidence of standing water. Presence of wetland species can also be used as an indicator of extended ponding and saturated soils. If there is standing water, it is likely that one of the system layers are not functioning properly or are clogged. This can be due to several factors including accumulation of excess debris that can clog the system, compaction of the media layers, or long-term accumulation of fines along the growth media and mulch interface. Initial steps to address this issue should include removal of accumulated debris and sediments. Additionally, scarifying the growth media surface can increase infiltration capacity. All underdrain pipes in the system should be flushed and/or vacuumed once a year to prevent sediment buildup and clogging. If these steps fail to remedy the problem, some of the layers may need to be replaced to restore full function. It is recommended to try and identify which layer needs replacing rather than replacing the entire system. To do this, perform double ring infiltrometer testing at each layer by digging down to the interface of each layer and performing a test. Prevention of future accumulation of debris and sediments may necessitate pretreatment.
- SP2:** The tree box filter system should be inspected monthly for evidence of debris and sediment accumulation. Debris and sediment accumulation should be removed using manual methods and pipes should be flushed to prevent future accumulation and clogging. Prevention of future accumulation of debris and sediments may necessitate pretreatment to prevent frequent clogging of media.

### **3.9.2 Water Quality Performance Monitoring Guidance for Tree Box Filter Systems with Underdrains**

Understanding the true performance of tree box filter systems will require adequate monitoring to ensure proper characterization of the practice. Optional water quality monitoring guidance can be found in **Appendix 3C**.

## **3.10 Design Calculations Example for Tree Box Filter Systems**

For this example, it is assumed that a 3-acre pasture site located within the boundaries of the SJRWMD is to be developed into a high-density commercial site. Soil types are dual-hydrologic soils group (HSG) A/D. In scenarios where the soil type is a dual-hydrologic group, it is recommended to use the second letter for a more conservative estimate. The calculations presented below demonstrate how to design a tree box filter system in high groundwater conditions to

achieve the required water quality treatment. It is noted that the following example calculation is for projects within special basins, which can be found in FAC 62-330.

The first step is to determine the required treatment volume per the water management district (WMD) and the County criteria. As this practice is a dry detention based practice, the water quality benefit would be associated with the volume of water that is captured and filtered through the BAM enhanced system. Thus, the SJRWMD criteria for dry detention is the relevant water quality criteria for this project. A summary of pre- and post- development conditions are presented below followed by details of the tree box filter design, the required treatment volume, and the final size of the system.

- Site conditions summary
  - Pre-development conditions
    - Land use: 3-acre site, pasture
    - Soil types: HSG A/D
  - Post-development conditions
    - Land use:
      - 2.4-acre site high density commercial
      - 0.6 acre will be open space (**20% open space requirement**)
    - Soil types: HSG A/D
    - Impervious areas:
      - Commercial area will be **60% impervious**
      - 1.8 acres will be impervious
- Proposed LID practice summary
  - Proposed tree box filter system is to have the following media layers:
    - 8 inch #57 stone
    - 2 inch #89 stone
    - 2 inch coarse sand
    - 12 inch BAM
    - 6 inch growth media
    - 3 inch hard mulch layer
    - Florida Friendly Landscaping
  - This system has a perforated underdrain with 6 inch diameter to recover volume
- Determination of required treatment volume
  - As previously stated, the proposed system is a dry detention practice. Based on the SJRWMD ERP handbook vol. 2 (SJRWMD, 2018), the water quality treatment volume is either a) 1 inch of runoff or b) 2.5 inches of runoff from the impervious area; whichever is greater.
    - a):  $\frac{3 \text{ ac} (1 \text{ in})}{12 \text{ in/ft}} = 0.25 \text{ ac} - \text{ft}$
    - b): 2.5 inches over the impervious area:  $\frac{1.8 \text{ ac} (2.5 \text{ in})}{12 \text{ in/ft}} = 0.375 \text{ ac} - \text{ft}$

- Since the 2.5 inches of runoff over the impervious area produces the greater treatment volume, this is the value required by the SJRWMD
  - Per the current state special basin criteria, as listed in FAC 62-330, water quality standard, an additional 50% treatment volume is required. This is calculated as:
    - $0.375 \text{ ac} - \text{ft} * 1.5 = 0.5625 \text{ ac} - \text{ft}$
    - Therefore, the total treatment volume required for this project is 0.5625 acre-feet
- Based on the above water quality treatment volume determination, the tree box filter system must provide 0.5625 acre-feet of storage. Tree box filters come in standard sizes, and the storage volumes in each tree box filter should be determined. The total treatment volume required would be divided by the total tree box volume to determine the number of tree box filters required. This is achieved easiest using a spreadsheet so values can be quickly and easily changed until the treatment volume is achieved.
  - Specifically, each aggregate layer is multiplied by the depth, area, and porosity to determine the water volume provided
  - The ponding volume is determined using the methods presented in **Section 3-2**, above
  - Following this process, a total area of 0.857 acre was determined
- Based on this, a tree box filter system with an 8 inch #57 stone layer, 2 inch #89 stone layer, 2 inch coarse sand layer, 12 inch BAM layer, 6 inch growth media layer, and 3 inch mulch layer would need to be 0.857 acre to provide sufficient treatment for a 3 acre high intensity commercial site. It is unlikely that one tree box filter will provide the sufficient treatment required for a 3 acre site, so it is recommended that multiple tree box filters are used to meet the needs. With the largest pre-cast concrete tree box filter being 128 square feet, this system will require 292 tree box filters to fulfill the nutrient removal needs. However, it should be noted that there are different designs for different applications; for example, a tree box used for a linear project would be a different design.
  - Implementing 292 tree box filters in a 3 acre watershed may not be feasible, but can be a critical component of a treatment train to help meet site water quality criteria.
  - It is noted that the example problem sizing of the tree box filter system is only for pollutant treatment purposes, not for flood control purposes. However, the tree box filter system will provide some flood control, resulting in a smaller pond needed for flood control elsewhere on the site.
- Since this system has an underdrain, the capacity of the underdrain pipe must be checked to ensure that the pipe can convey the design flow rates. This can be readily calculated using a modified form of the Manning's Equation:

$$d_i = \left( \frac{1630 Q_p n}{\sqrt{S}} \right)^{\frac{3}{8}}$$

where:  $d_i$  = Inside pipe diameter (in)

$n$  = Manning's coefficient of roughness

$Q_p$  = Peak design discharge rate (cfs)

$S$  = Slope of the pipe (ft/ft)

If the pipe cannot convey the peak flow rate, additional head losses must be considered in the recovery time, or a larger size pipe must be used.



## REFERENCES

1. Minnesota Stormwater Manual (2022). Soil water storage properties.  
[https://stormwater.pca.state.mn.us/index.php/Soil\\_water\\_storage\\_properties](https://stormwater.pca.state.mn.us/index.php/Soil_water_storage_properties)
2. Woessner, W.W. and Poeter, E. P. (2022). Hydrogeologic Properties of Earth Materials and Principles of Groundwater Flow. ISBN: 978-1-7770541-2-0. <https://gw-project.org/books/hydrogeologic-properties-of-earth-materials-and-principles-of-groundwater-flow/>
3. SFWMD (2016). Environmental Resource Permit Applicant's Handbook Volume 2.  
[https://www.sfwmd.gov/sites/default/files/documents/swerp\\_applicants\\_handbook\\_vol\\_ii.pdf](https://www.sfwmd.gov/sites/default/files/documents/swerp_applicants_handbook_vol_ii.pdf)
4. SJRWMD (2018). Environmental Resource Permit Applicant's Handbook Volume 2.  
<https://www.sjrwmd.com/static/permitting/PIM-20180601.pdf>

## **APPENDIX 3A**

# **Tree Box Filter with Underdrains Operation and Maintenance Checklist**

<b>Inspection and Maintenance Checklist for Tree Box Filters with Underdrains</b>			
Facility Name and Address:			
Date of Inspection:			
Site Conditions:	Excellent <input type="checkbox"/>	Good <input type="checkbox"/>	Adequate <input type="checkbox"/> Poor <input type="checkbox"/>
Date of Last Rain Event:			
Inspection Frequency Type:	Monthly <input type="checkbox"/>	Quarterly <input type="checkbox"/>	Annual <input type="checkbox"/>
<b>Inspection Activities</b>			
Visual inspections are an integral part of system maintenance. Inspection includes monitoring for drainage, debris and sediment accumulation, vegetation health and coverage, and surface deterioration.			
Inspection Item	Checked (Y/N)	Maintenance Needed (Y/N)	Corrective Action/Comments
<b>TREE BOX FILTER SURFACE (Frequency – Monthly)</b>			
BS1. Evidence of erosion (i.e., visible rills or sediment accumulation)			
BS2. Mulch layer is still in place (depth of at least 3 in)			
BS3. Inflow and overflow points in working order			
<b>VEGETATION MANAGEMENT (Frequency – Quarterly)</b>			
VM1. Evidence of dead or unhealthy trees			
VM2. Is tree community composition still according to approved plans?			
VM3. Do trees appear well maintained/manicured			

<b>SYSTEM PERFORMANCE (Frequency – Monthly)</b>			
SP1. Evidence of standing water, flushing/vacuuming pipes			
SP2. Debris and sediment accumulation			
<b>OVERALL CONDITION OF FACILITY</b>			
In accordance with approved design plans? (Y/N)			
Maintenance required as result of deficiencies detailed above? (Y/N)			
Date by which maintenance must be completed: (Y/N)			
<b>NOTES</b>			

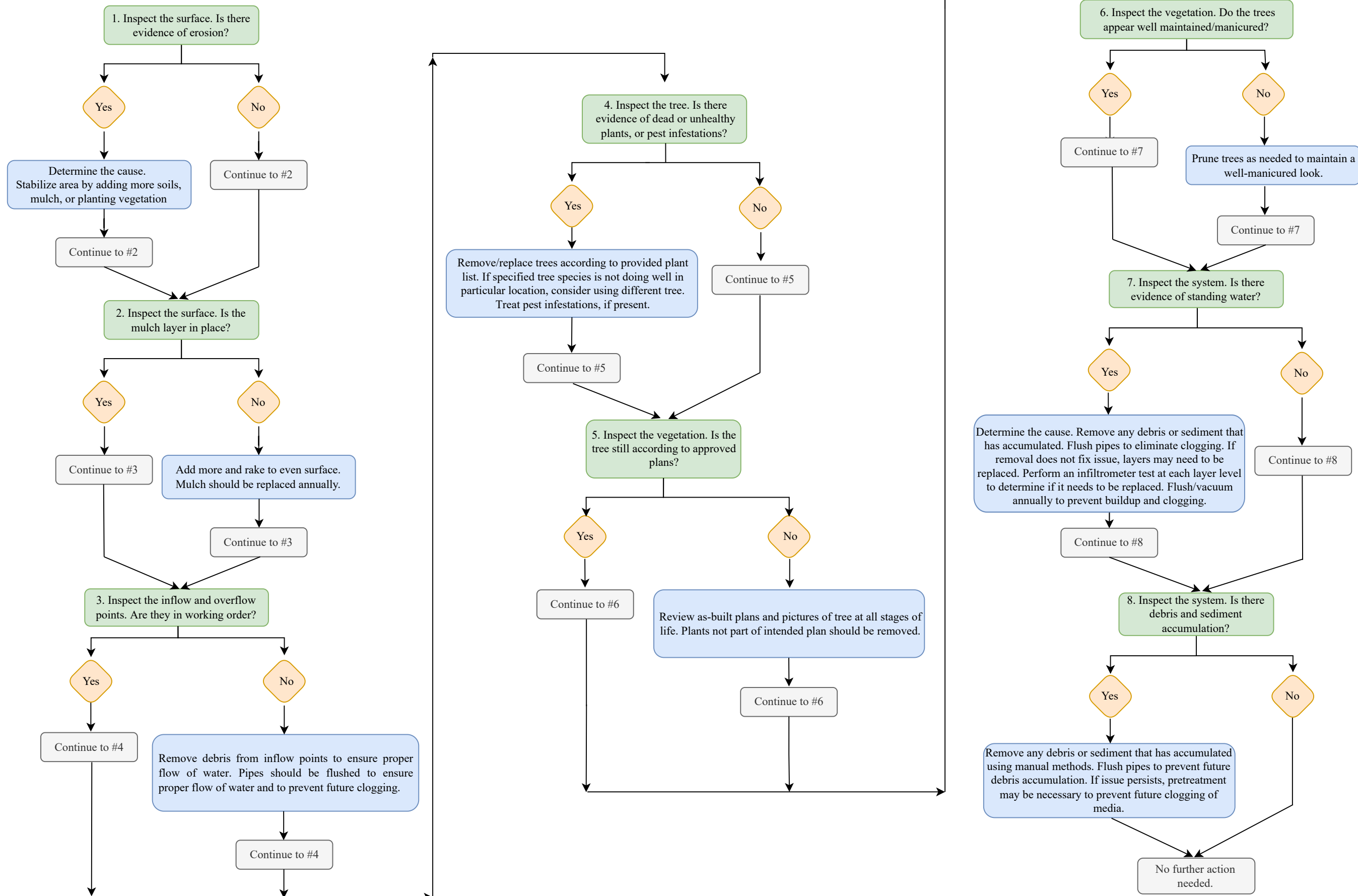
<b>CERTIFICATION SIGNATURE</b>	
Company Name:	
Company email, address, and phone number:	
Name of Inspector:	
Inspector Signature:	

Note: Take a minimum of 5 representative photos of the tree box filter area, attach the photos to the form, and include any additional observations in the notes section prior to submission. Make sure to include pictures of any inflow/outflow points, the vegetation, and any other aspects of the tree box filter system.

## **APPENDIX 3B**

# **Tree Box Filter with Underdrains Operation and Maintenance Flow Chart**

# Tree Box Filter with Underdrain Operation and Maintenance



## **APPENDIX 3C**

# **Tree Box Filter with Underdrains Water Quality Performance Monitoring Guidance**



## Water Quality Performance Monitoring

To determine if the bioretention system is performing as intended, water quality monitoring should be performed. This includes sampling water at key locations within the tree box filter system as well as accumulated sediment and debris removed as part of maintenance activities. To properly monitor this LID practice the pollutant flow path, removal mechanisms, and the downstream waterbody of interest needs to be identified. To aid in the design of a proper tree box filter system monitoring program, the general steps below can be followed. It is noted that the below sampling recommendations are relevant for a tree box filter system that is installed in a region with a seasonal high groundwater table.

Define the treatment objective and the downstream waterbody of interest. Specifically, determine the water quality parameter(s) of interest and if the goal is to reduce loading to a surface waterbody or groundwater. This will dictate how the practice should be monitored.

- a. If the waterbody of interest is a surface water, then the bulk of the water quality benefit is associated with the volume reduction provided by the practice. Thus, monitoring should focus on characterization of the flow and parameter EMCs of water at the system locations specified below.
  - i. The system inflow
  - ii. The system overflow
- b. Additionally, nutrients and other pollutants can be removed from the system in the form of maintenance activities that are performed, e.g., removal of vegetation, removal of sediments, removal of organic debris. Thus, the mass of pollutants associated with the following should also be characterized.
  - i. Accumulated sediments and organic debris
  - ii. Removed vegetation
- c. If the waterbody of interest is the groundwater, then, in addition to monitoring the inflow to the tree box filter system, sampling of the water entering the ground should also be performed.
  - i. To sample water as it enters the ground, a lysimeter is to be installed in the tree box filter system so that it can be sampled. Guidance on how to construct and install a lysimeter can be found here: <https://edis.ifas.ufl.edu/publication/AE554>. The sizing of the lysimeter should be based on the desired sample volume so that the lysimeter can hold the anticipated volume.

- d. Flow monitoring should be performed using an area-velocity probe, or other equipment appropriate for continuous estimation of flow, such as the ISCO 2150 area velocity probe.
- e. Stormwater sampling should be performed using auto-sampler equipment capable of collecting time- or flow-weighted composite samples, including but not limited to ISCO 6712 autosamplers. It is noted that, if possible, refrigerated autosamplers are preferred as they are able to preserve samples quicker than field personnel can collect samples.
- f. Storm events that are typical of Central Florida weather are to be sampled to evaluate typical performance of tree box filter systems. A rain gauge is to be installed onsite to measure rainfall at the site.
- g. System performance can be determined as the mass that is retained or removed from the tree box filter system. This is determined as the difference in the mass entering the system and the mass leaving the system.
  - i. The mass entering the system can be determined based on the flow and constituent EMC. It is noted that while autosamplers are effective at characterizing the fine particulates and dissolved pollutants in stormwater, they are not effective at capturing coarser sediments and organic material. As such, when such materials are removed from tree box filter systems as part of maintenance activities, the mass of constituent associated with these activities must be considered as part of the loading to the system as well as loading removed from the system.
  - ii. One mass output is the mass leaving as surface runoff. This can be determined based on the overflow volume and constituent EMC.
  - iii. Another mass output is the mass of pollutants associated with removal of debris, sediments, or vegetation due to maintenance activities performed on the tree box filter system. This can be determined based on the mass of material, constituent content, and moisture content of materials removed.
  - iv. The mass leaving to the groundwater can be determined based on the difference in inflow and overflow volume, and the constituent EMC as measured from the lysimeter.
  - v. The performance of the system can be determined based on the difference between the mass entering the tree box filter system and the mass discharged to the downstream waterbody of interest.

# **ATTACHMENT 4**

## **Infiltration Planter Boxes**



engineers | scientists | innovators



# STORMWATER LOW IMPACT DEVELOPMENT MANUAL, VOLUME 2

## ATTACHMENT 4

# INFILTRATION PLANTER BOXES

*Prepared for*

**Orange County Planning Division**

201 S. Rosalind Ave., 2<sup>nd</sup> Floor  
Orlando, FL 32802

**Orange County Public Works**

4200 S John Young Parkway  
Orlando, FL 32839

**Orange County Environmental Protection Division**

3165 McCrory Place, Suite 200  
Orlando, FL 32803

*Prepared by*

Geosyntec Consultants, Inc.  
3504 Lake Lynda Drive, Suite 155  
Orlando, FL 32817

Project Number: FW8213

December 2023

**TABLE OF CONTENTS**

4. BACKGROUND ..... 4-1

4.1 Design Features of Typical System..... 4-1

4.2 Design Guidance and Criteria ..... 4-3

4.3 Site Suitability ..... 4-5

4.4 Pollutant Removal Efficiencies ..... 4-5

4.5 Regulatory and Permitting Considerations..... 4-5

4.6 Construction Considerations ..... 4-6

4.7 Design Details and Specifications ..... 4-7

4.8 Artist Renderings..... 4-10

4.9 Inspection, Maintenance, and Monitoring..... 4-10

4.9.1 Inspection Steps and Checklists for Infiltration Planter Boxes without Underdrains ..... 4-11

4.9.2 Water Quality Performance Monitoring Guidance for Infiltration Planter Boxes without Underdrains ..... 4-13

4.9.3 Inspection Steps and Checklists for Infiltration Planter Boxes with Underdrains ..... 4-13

4.9.4 Water Quality Performance Monitoring Guidance for Infiltration Planter Boxes with Underdrains ..... 4-16

4.10 Design Calculations Example for Well-Draining Sandy Soils ..... 4-16

4.11 Design Calculations Example for Poor-Draining / High Water Table Soils or Sensitive Groundwater Areas..... 4-18

**LIST OF TABLES**

Table 4-1. Porosity of Materials used in Infiltration Planter Boxes ..... 4-3

**LIST OF FIGURES**

Figure 4-1: Infiltration Planter Box with Deep Groundwater Table Details ..... 4-8

Figure 4-2: Infiltration Planter Box with Shallow Groundwater Table Details..... 4-9

Figure 4-3: Infiltration Planter Box in an Urban Landscape Setting ..... 4-10

## **LIST OF APPENDICIES**

- Appendix 4A: Infiltration Planter Box without Underdrains Operation and Maintenance Checklist
- Appendix 4B: Infiltration Planter Box without Underdrains Operation and Maintenance Flow Chart
- Appendix 4C: Infiltration Planter Box without Underdrains Water Quality Monitoring Guidance
- Appendix 4D: Infiltration Planter Box with Underdrains Operation and Maintenance Checklist
- Appendix 4E: Infiltration Planter Box with Underdrains Operation and Maintenance Flow Chart
- Appendix 4F: Infiltration Planter Box with Underdrains Water Quality Monitoring Guidance

## ACRONYMS AND ABBREVIATIONS

BAM	Biosorption Activated Media
BMAP	Basin Management Action Plan
BMP	Best Management Practice
CEC	Cation Exchange Capacity
DCIA	Directly Connected Impervious Area
DEM	Digital Elevation Model
EMC	Event Mean Concentration
EPA	Environmental Protection Agency
ERP	Environmental Resource Permit
FAC	Florida Administrative Code
FDEP	Florida Department of Environmental Protection
GSI	Green Stormwater Infrastructure
H&H	Hydrologic and Hydraulic Modeling
ICPR4	Interconnected Channel and Pond Routing Model
LID	Low Impact Development
MS4	Municipal Separate Storm Sewer System
N <sub>2</sub>	Nitrogen Gas
NH <sub>3</sub>	Ammonia
NO <sub>2</sub>	Nitrite
NO <sub>3</sub>	Nitrate
NOAA	National Oceanic and Atmospheric Administration
NPDES	National Pollutant Discharge Elimination System
NWL	Normal Water Level
OFS	Outstanding Florida Springs
OFW	Outstanding Florida Waters
PFA	Primary Focus Area
RAP	Reasonable Assurance Plan
SFWMD	South Florida Water Management District
SJRWMD	St. Johns River Water Management District
SWMM	Storm Water Management Model

SWMP	Stormwater Management Program
Tc	Time of Concentration
TMDL	Total Maximum Daily Load
TN	Total Nitrogen
TP	Total Phosphorus
UF/IFAS	University of Florida/Institute of Food and Agricultural Sciences
VBS	Vegetated Buffer Strips
WERF	Water Environment Research Foundation
WMD	Water Management District



## **4. BACKGROUND**

This attachment provides detailed information on infiltration planter box design. Design features of typical systems as well as design guidance and criteria are presented and discussed. Additionally, site suitability, pollutant removal efficiencies, regulatory and permitting considerations, construction considerations, and design details and specifications are presented. Finally, two example problems are presented to demonstrate design calculations for infiltration planter boxes in areas with poor draining soils/elevated water tables and areas with well draining soils/deep water tables.

### **4.1 Design Features of Typical System**

Infiltration planter box systems can be designed similarly to traditional retention systems, where they store and infiltrate water, or as a detention system, where they contain an underdrain to collect water that has been filtered through system aggregate layers including an optional BAM layer. However, a few distinguishable features include being able to be constructed alongside a building to treat stormwater that comes from rain gutters. Similarly to bioretention systems, infiltration planter boxes have high permeability layers to increase water storage, and vegetation, specifically including flowering vegetation. Infiltration planter boxes discussed in this manual has two primary designs discussed above, namely one without an underdrain and one with an underdrain. Infiltration planter boxes without an underdrain is typically used in applications where the system has 3 feet or more of separation between the bottom of the basin and the SHGWT. These systems typically contain the following layers as a minimum, from system bottom to top:

- 2 inches (minimum) of #89 stone directly on subbase (this optional layer can add to the water storage of the system),
- 6 inches (minimum) of #57 stone (this optional layer can add to the water storage of the system),
- 2 inches (minimum) of #89 stone (this optional layer can add to the water storage of the system),
- 2 inches (minimum) of coarse sand (this optional layer can add to the water storage of the system),
- 1 foot (minimum) of BAM (this optional layer can be added to protect sensitive groundwater conditions),
- 6 inches (minimum) of growth media, and
- 3 inches (minimum) of mulch.

The above are examples of stone gradations that can be used. However, other stone gradations can also be used but they need to be selected such that the pore sizes of the base material are not sufficiently large to allow the top layer to fill in voids. Some mixing at interface, interstitial mixing, is expected but a subsequent layer should be able to be built up. This bridging should eliminate need for filter fabrics since they are prone to clogging. Many nutrient removal practices encourage growth of biofilm for the uptake/removal mechanism. While performing an inherent beneficial

process, if excess biofilm concentrates along a filter fabric, it will choke out the pore resulting in a significant reduction in permeability and potentially clogging the fabric. It is noted that a geotextile filter fabric could be beneficial if installed on the sides of the infiltration planter box to minimize mixing with parent soils. It is noted that no filter fabric should be installed on the interface of the infiltration area. The points of inflow should leverage hard or soft armoring techniques, such as a splash block, to protect against erosion. Florida native plants appropriate for the expected conditions, i.e., water depth/duration, amount of light, etc. are to be planted in the infiltration planter box system. Refer to **Appendix A** of the accompanying Volume 1 of this LID manual for plant lists appropriate for the different conditions found within the County as well as guidance on choosing trees based on soil volume available.

For an infiltration planter box system that does not have 3 feet of separation between the bottom of the basin and the SHGWT, or has poor infiltrating soils, an underdrain is required to provide recovery for the system. These systems typically have the following layers as a minimum, from system bottom to top:

- 8 inches (minimum) of #57 stone,
- 2 inches (minimum) of #89 stone,
- 2 inches (minimum) of coarse,
- 1 foot (minimum) of BAM,
- 6 inches (minimum) of growth media, and
- 3 inches (minimum) of mulch.

These are examples of stone gradations that can be used, however, other stone gradations can also be used. It is noted that should other stone gradations be used, they need to be selected such that the pore sizes of the base are not sufficiently large to allow the top layer to fill in voids. Some mixing at the interface is normal but a subsequent layer should be able to be built up. The intent of the different stone bridging layers is to eliminate the need for filter fabrics since they are prone to clogging. This is due to that fact that this practice/media encourages the growth of biofilm, which while enhances nutrient removals, it can choke out pores if it concentrates along filter fabric interface.

A geotextile filter fabric should be installed on the sides and bottom of the infiltration planter box to minimize mixing with parent soils. An underdrain, minimum 6 inch diameter perforated pipe, should be installed to collect water that percolates through the system and direct the collected water to the existing drainage system. Additionally, an overflow pipe (minimum 6 inch diameter) and cleanout port (minimum 6 inch diameter) should be installed to ensure proper overflow and that the system can be maintained.

The points of inflow should leverage hard or soft armoring techniques, such as a splash block, to protect against erosion. Florida native plants appropriate for the expected conditions, i.e., water depth/duration, amount of light, etc. are to be planted in the infiltration planter box system. Refer to **Appendix A** of the accompanying Volume 1 of this LID manual for plant lists appropriate for

the different conditions found within the County as well as guidance on choosing trees based on soil volume available.

## 4.2 Design Guidance and Criteria

Infiltration planter box systems are typically used to help reduce the volume of runoff leaving a site and provide filtration and sorption of pollutants by the plants and different media layers. While these systems can alleviate flooding, they will often by themselves not have the capacity to provide the entirety of site flood storage requirements. While these systems are typically incorporated into a design to meet a water quality criteria, the volume provided can be used to off-set flood control volume requirements. Based on this, sizing of these systems will typically be based on the required water quality treatment that must be provided. This sets forth a presumptive criteria that water quality targets are being met if this level treatment is provided. The design example presented below demonstrates the calculation methodology necessary to determine the appropriate water quality treatment volume.

Infiltration planter box systems are composed of specific materials that each serve a specific function within the system. Rock aggregate layers provide water storage, facilitate drainage, provide bridging layers to minimize movement of different materials to different layers, and evenly distribute water. The coarse sand layer performs similar functions as the rock aggregate layers, providing some water storage, bridging, and facilitating drainage. The mulch layer is intended to hold moisture in the system and minimize weed growth. The water storage associated with these layers can be determined by multiplying the material depth by the area and the porosity (**Table 4-1**).

**Table 4-1. Porosity of Materials used in Infiltration Planter Boxes**

Material	Recommended Porosity Value	Reference
#89 Stone	25%	BMPTrains, 2020, v4.3.2
#57 Stone	21%	BMPTrains, 2020, v4.3.2
Coarse Sand	18%	Woessner & Poeter, 2020
BAM	20%	BMPTrains, 2020, v4.3.2
Mulch	70%	Sustainable Technologies, 2022
Growth Media (Sandy Loam)	14%	Minnesota Stormwater Manual, 2022

The ponding volume on top of the mulch layer can be determined using the equation below:

$$(A_1 \times D) + \left( (A_2 - A_1) \times D \times \frac{1}{2} \right) = V$$

Where:

$A_1$  = Area of the bottom slice of the ponding depth (ft<sup>2</sup>)

$A_2$  = Area of the top slice of the ponding depth (ft<sup>2</sup>)

$D$  = Ponding depth (ft)

$V$  = Volume of the ponding area (ft<sup>3</sup>)

Florida Friendly Landscaping should be leveraged and appropriate plants chosen based on the expected conditions. Additionally, consideration for the mature plant size should be considered when selecting plants. If the practice used is not going to provide sufficient root zone and soil volume needed for the mature plant, it is recommended to use something smaller and more appropriate. Along those lines, due to the scale of typical infiltration planter boxes, many tree species will not be appropriate for these systems. The plant lists supplied in **Appendix A** of the accompanying Volume 1 of this LID manual should be referred for guidance on plant selection as well as guidance on choosing trees based on soil volume available.

Finally, some additional considerations are related to how water enters or leaves these systems. Inflow points should be protected using either a hard or soft armoring approach, depending on the anticipated flow rates and velocities. The State of Florida Erosion and Sediment Control Designer and Reviewer Manual (July 2013) provides guidance on acceptable velocities for different armoring practices. Similarly, overflow from the infiltration planter box should be protected. An internal piped overflow, minimum of 6 inch diameter, could also be used. Infiltration planter in areas that incorporate an underdrain into the design must ensure that sufficient underdrains be provided to drain the treatment volume within 72 hours (SFWMD, 2016; SJRWMD, 2018). This can be checked using a modified version of the Manning's Equation:

$$d_i = \left( \frac{1630 \times Q_p \times n}{\sqrt{S}} \right)^{3/8}$$

Where:

$d_i$  = Inside pipe diameter (in)

$n$  = Manning's coefficient of roughness

$Q_p$  = Peak discharge rate (cfs)

$S$  = Slope of pipe (ft/ft)

### **4.3 Site Suitability**

Infiltration planter boxes should be strategically placed based on site conditions. The natural site topography should be considered and placement be congruent with the natural low spots within the site. It is noted that it is not recommended to install infiltration planters where slopes are 10% or greater. Additionally, infiltration planter box design should incorporate an underdrain for systems that have less than 3 feet of separation between the SHGWT and the system bottom. It is recommended to incorporate a media layer in systems with underdrains, in sensitive groundwater areas, or in special basins to provide additional nutrient removal.

It is good engineering practice to consider other infrastructure that could be impacted by the proposed infiltration planter boxes such as road bases and/or building foundations. Additionally, nearby wastewater treatment practices should be considered and infiltrating practices, such as infiltration planters, should not be placed over a septic drainfield and must be at least 75 feet away from public or private potable wells.

As infiltration planter boxes are vegetation based practices, it is important to consider sun requirements as well as moisture conditions. The vegetation guidance provided in **Appendix A** of the accompanying Volume 1 of this LID manual should be referenced for guidance on plant selection

### **4.4 Pollutant Removal Efficiencies**

The pollutant removal efficiency for infiltration planter boxes is based on the removal mechanisms of this practice. In areas where stormwater can be infiltrated and are not within sensitive groundwater areas, it is assumed that the pollutants associated with the water that infiltrates into the ground are removed. If the area has sensitive groundwater conditions and loadings to the groundwater is of interest, such as the Wekiwa Springs PFA, a BAM layer is recommended to provide treatment of water as it infiltrates into the ground and the removal efficiency relies on the characteristics of the BAM layer. To determine the water quality benefit, estimate the average annual volume of water infiltrated into the ground, multiply by the appropriate event mean concentration (EMC), and then multiply by the removal efficiency of the pollution control media used. The average annual volume of water infiltrated can be estimated by leveraging continuous simulation modeling or the methods of Harper and Baker (2007). Additionally, there are models and calculation tools that are based on the Harper and Baker (2007) method, such as the BMP Trains model, which can be used to estimate the water quality benefit of implementing infiltration planter boxes.

### **4.5 Regulatory and Permitting Considerations**

Applicable criteria for the governing water management district are to be applied on a site by site basis. It is anticipated that infiltration planter projects will require an Environmental Resource Permit (ERP) from the corresponding water management district (SFWMD, 2016; SJRWMD, 2018). For a project to qualify for an ERP it must be demonstrated that the proposed project will not result in upstream flooding or increases in peak stage, or not result in increases in peak

discharge rates from the site, as well as meet water quality treatment requirements. It is noted that stormwater treatment performance standards vary depending on a number of site factors and are summarized as follows:

- If the proposed system discharges directly/indirectly to surface waters, it falls under the MS4 and NPDES rules,
- If the proposed system discharges directly to an Outstanding Florida Waterbody (OFW) or Outstanding Florida Springs (OFS), it falls under the FDEP OFW and OFS rule,
- If the proposed system is within waterbodies with TMDLs, it falls under the EPA rule which delegates the enforcing authority to FDEP, and
- If the proposed system is within watersheds that are on the verified impaired waterbodies list, sensitive groundwater areas, or waterbodies with BMAPS, 4b, or 4e plans, it falls under the FDEP rule.

The specific water quality treatment volume required varies depending on the criteria listed above. Additionally, for basins that do not currently require that additional 50% treatment volume, this manual requires the criteria be provided in all basins in Orange County, in addition to the relevant water management district requirements. This requirement may be affected by the pending statewide stormwater rule and should be evaluated after adoption of the rule, as this manual was started prior to the adoption of the statewide stormwater rule.

## 4.6 Construction Considerations

The following construction considerations should be considered when building an infiltration planter box:

- Utilities should be contacted prior to digging to ensure it is clear to dig, otherwise relocation of the utilities will be necessary. The area to be excavated should be determined based on calculations done to meet nutrient removal needs.
  - No utility or other infrastructure shall be placed in the location of the LID structure that would interfere with the function or maintenance of the structure.
- Every effort should be made to minimize compaction of soils where the infiltration planter box is proposed.
- A sufficient staging area should be provided where:
  - Plants can get sufficient sunlight and be easily watered to keep them alive prior to planting, and
  - Growth media, pollution control media, and rock aggregates can be stored without risk of contamination or mixing with site soils.
- Appropriate erosion and sediment control practices be incorporated to minimize site erosion and sediment loss.
- Smaller trees are more suitable for infiltration planters, while larger trees are better for tree box filters.

- The plants selected should be able to withstand water fluctuations. Typical plants used in infiltration planters include yaupon holly, fridge tree, flatwoods plum, roundpod St. John's wort, dwarf wild coffee, lovegrass, muhly grass, and Florida gamma grass.

## **4.7 Design Details and Specifications**

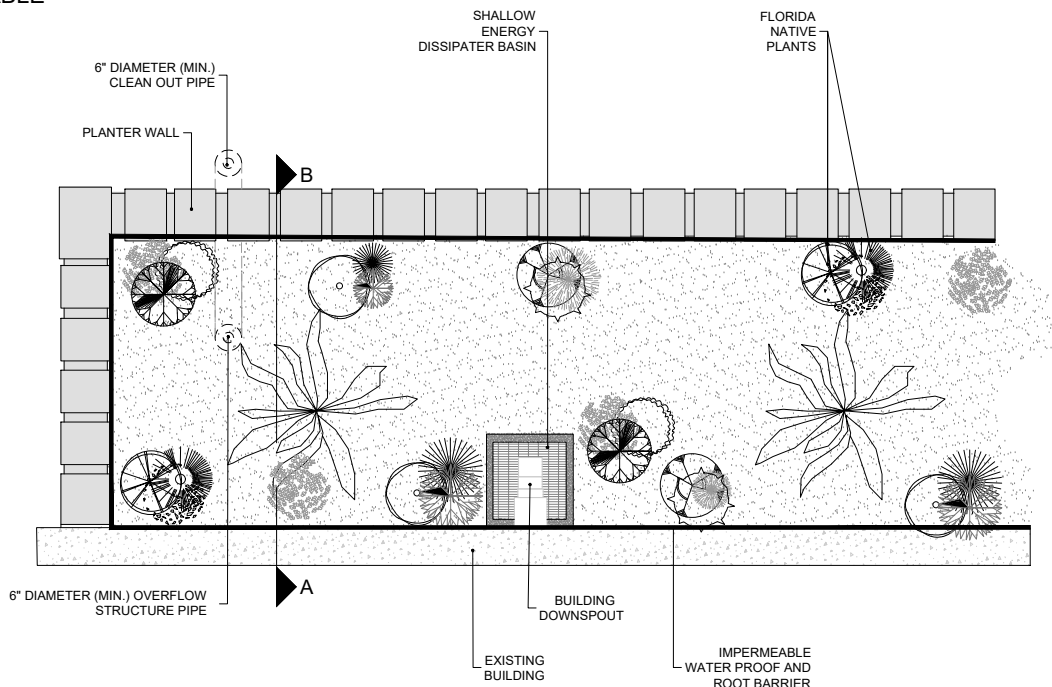
As part of this effort, design details and general specifications were developed. **Figure 4-1** and **Figure 4-2** show the relevant design details for infiltration planter boxes both without and with an underdrain. There are two design options for the infiltration planter which include infiltrating and underdrain. General specifications are also included on each detail.



PLAN

INFILTRATION PLANTER BOX WITH DEEP GROUNDWATER TABLE

(NOTE)  
N.T.S.



NOTES:

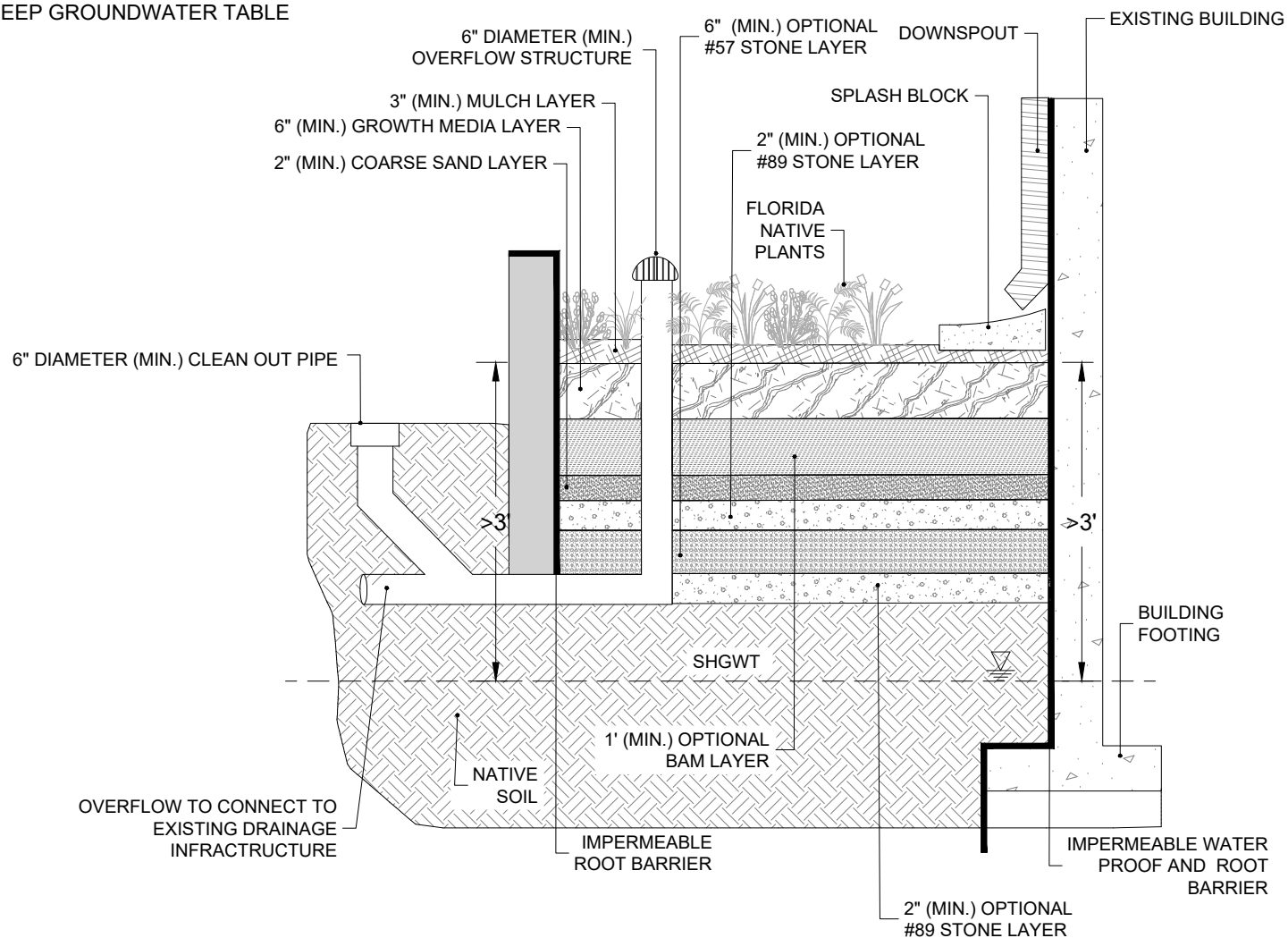
1. CONTACT UTILITY COMPANY AND ENSURE UTILITY LINES ARE PROPERLY LOCATED PRIOR TO DIGGING OR TRENCHING.
2. THE MULCH LAYER IS INTENDED TO MINIMIZE EROSION, MINIMIZE WEEDS, AND HOLD MOISTURE IN THE SYSTEM. THE MULCH SHOULD CONSIST OF LARGE CHIP HARDWOOD MULCH (CYPRESS MULCH IS NOT RECOMMENDED).
3. THE GROWTH MEDIA IS INTENDED TO PROMOTE INFILTRATION AS WELL AS HEALTHY PLANT GROWTH. GROWTH MEDIA SHALL BE A MINIMUM OF 6 INCHES IN DEPTH AND SHALL BE COMPOSED OF 50% COARSE SAND (ASTM C-33), 25% TOPSOIL (LESS THAN 5% FINES PASSING #200 SIEVE), AND ORGANIC COMPOST (LEAF AND MULCH MIX). MEDIA SHALL ACHIEVE INFILTRATION RATES THAT EXCEEDS 2 INCHES PER HOUR.
4. THE OPTIONAL BAM LAYER IS INTENDED TO PROVIDE TN AND TP REMOVAL FROM STORMWATER AS IT INFILTRATES INTO THE GROUND. THIS LAYER IS INTENDED TO BE USED IN AREAS OF SENSITIVE GROUNDWATER, SUCH AS WITHIN THE WEKIWA SPRINGS SPRINGSHED. BAM IS A GENERIC TERM FOR ANY MEDIA THAT LEVERAGES BIOLOGICAL, CHEMICAL, AND/OR PHYSICAL PROCESSES FOR POLLUTANT REMOVAL. MEDIA SHALL ACHIEVE INFILTRATION RATES THAT EXCEEDS 2 INCHES PER HOUR.
5. THE COARSE SAND LAYER IS INTENDED TO ACT AS A SUPPORT LAYER FOR THE BAM AND PROVIDE A BRIDGING LAYER TO PREVENT THE MIGRATION OF BAM MEDIA FROM ENTERING THE OPTIONAL STONE RESERVOIR LAYERS BELOW. THE COARSE SAND SHOULD BE WASHED AND CONSISTENT WITH ASTM C-33. SAND SHALL BE FREE FROM OBJECTIONAL WEEDS, LITTER, SODS, STIFF CLAY, STONES, ROOTS, TRASH, HERBICIDES, TOXIC SUBSTANCES, OR ANY OTHER CHEMICAL THAT MAY BE HARMFUL TO THE ENVIRONMENT.
6. THE OPTIONAL #89 STONE LAYER IS INTENDED TO ACT AS A BRIDGING LAYER AND INCREASE WATER STORAGE WITHIN THE SYSTEM. THE AGGREGATE SIZING SHOULD BE CONSISTENT WITH AASHTO M43, WITH A NOMINAL DIAMETER OF 3/8 OF AN INCH. ALL AGGREGATE STONE IS TO BE WASHED TO MINIMIZE THE INTRODUCTION OF FINES INTO THE SYSTEM.
7. THE OPTIONAL #57 STONE LAYER IS INTENDED TO ACT AS A STORAGE RESERVOIR TO INCREASE THE WATER STORAGE OF THE SYSTEM. THE AGGREGATE SIZING SHOULD BE CONSISTENT WITH AASHTO M43, WITH A NOMINAL DIAMETER OF 1.5 INCHES. ALL AGGREGATE STONE IS TO BE WASHED TO MINIMIZE THE INTRODUCTION OF FINES INTO THE SYSTEM.
8. THE OVERFLOW STRUCTURE IS INTENDED TO PROVIDE DRAINAGE OF EXCESS WATER PAST THE DESIGN VOLUME. IT IS TO BE INSTALLED WITH A SLOTTED DOME OVERFLOW TO PREVENT TRASH AND DEBRIS FROM ENTERING THE UNDERDRAIN. THE SUM OF THE SLOT OPENING SIZES IN THE SLOTTED DOME OVERFLOW MUST BE GREATER THAN THE AREA OF THE OPEN PIPE. THE MINIMUM PIPE DIAMETER CONSIDERED SHOULD BE 6 INCHES.



SECTION

INFILTRATION PLANTER BOX WITH DEEP GROUNDWATER TABLE

(NOTE)  
N.T.S.



INFILTRATION PLANTER BOX WITH DEEP  
GROUNDWATER TABLE  
LID MANUAL DETAILS  
ORANGE COUNTY; FLORIDA



FIGURE  
4-1

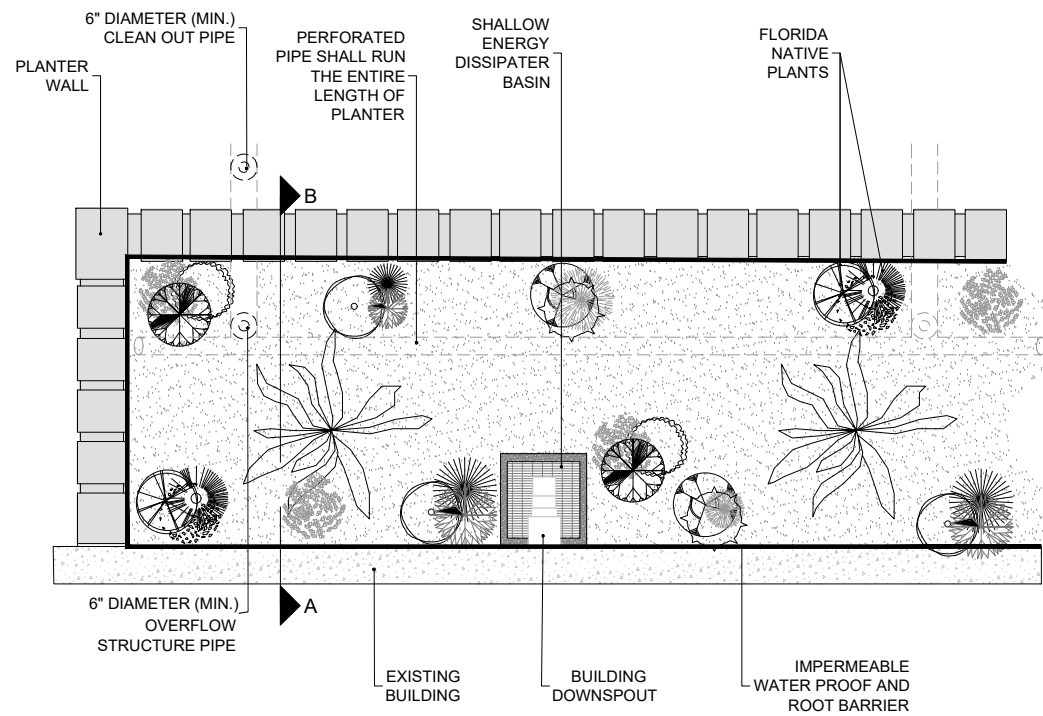




PLAN

INFILTRATION PLANTER BOX WITH SHALLOW GROUNDWATER TABLE

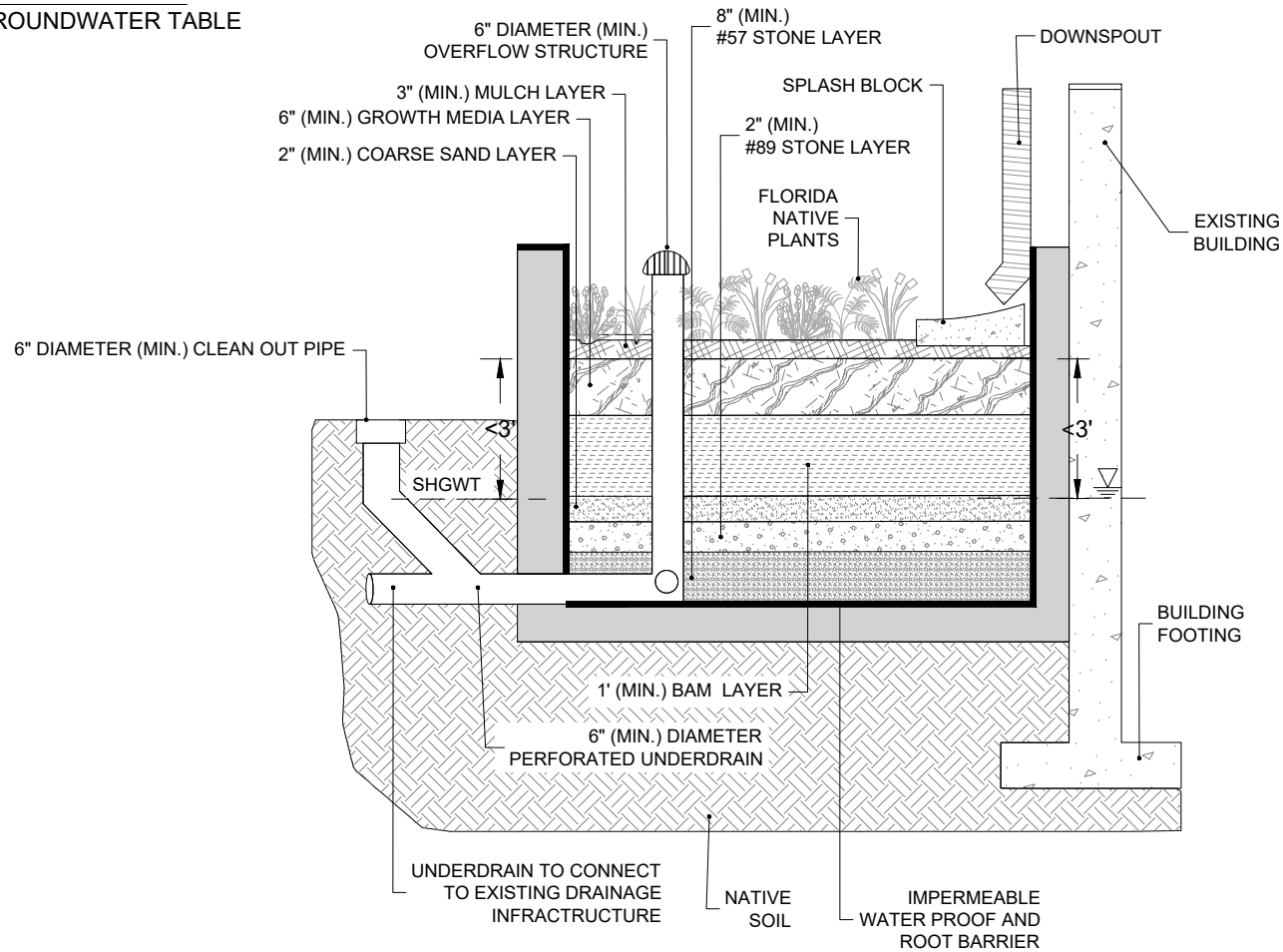
(NOTE)  
N.T.S.



SECTION

INFILTRATION PLANTER BOX WITH SHALLOW GROUNDWATER TABLE

(NOTE)  
N.T.S.



NOTES:

- CONTACT UTILITY COMPANY AND ENSURE UTILITY LINES ARE PROPERLY LOCATED PRIOR TO DIGGING OR TRENCHING.
- THE MULCH LAYER IS INTENDED TO MINIMIZE EROSION, MINIMIZE WEEDS, AND HOLD MOISTURE IN THE SYSTEM. THE MULCH SHOULD CONSIST OF LARGE CHIP HARDWOOD MULCH (CYPRESS MULCH IS NOT RECOMMENDED).
- THE GROWTH MEDIA IS INTENDED TO PROMOTE INFILTRATION AS WELL AS HEALTHY PLANT GROWTH. GROWTH MEDIA SHALL BE A MINIMUM OF 6 INCHES IN DEPTH AND SHALL BE COMPOSED OF 50% COARSE SAND (ASTM C-33), 25% TOPSOIL (LESS THAN 5% FINES PASSING #200 SIEVE), AND ORGANIC COMPOST (LEAF AND MULCH MIX). MEDIA SHALL ACHIEVE INFILTRATION RATES THAT EXCEEDS 2 INCHES PER HOUR.
- THE BAM LAYER IS INTENDED TO PROVIDE TN AND TP REMOVAL FROM STORMWATER BEFORE IT IS COLLECTED BY THE UNDERDRAIN PIPE. BAM IS A GENERIC TERM FOR ANY MEDIA THAT LEVERAGES BIOLOGICAL, CHEMICAL, AND/OR PHYSICAL PROCESSES FOR POLLUTANT REMOVAL. MEDIA SHALL ACHIEVE INFILTRATION RATES THAT EXCEEDS 2 INCHES PER HOUR.
- THE COARSE SAND LAYER IS INTENDED TO ACT AS A SUPPORT LAYER FOR THE BAM AND PROVIDE A BRIDGING LAYER TO PREVENT THE MIGRATION OF BAM MEDIA FROM ENTERING THE STONE RESERVOIR LAYERS BELOW. THE COARSE SAND SHOULD BE WASHED AND CONSISTENT WITH ASTM C-33. SAND SHALL BE FREE FROM OBJECTIONAL WEEDS, LITTER, SODS, STIFF CLAY, STONES, ROOTS, TRASH, HERBICIDES, TOXIC SUBSTANCES, OR ANY OTHER CHEMICAL THAT MAY BE HARMFUL TO THE ENVIRONMENT.
- THE #89 STONE LAYER IS INTENDED TO ACT AS A BRIDGING LAYER AND INCREASE WATER STORAGE WITHIN THE SYSTEM. THE AGGREGATE SIZING SHOULD BE CONSISTENT WITH AASHTO M43, WITH A NOMINAL DIAMETER OF 3/8 OF AN INCH. ALL AGGREGATE STONE IS TO BE WASHED TO MINIMIZE THE INTRODUCTION OF FINES INTO THE SYSTEM.
- THE #57 STONE LAYER IS INTENDED TO ACT AS A DRAINAGE LAYER TO FACILITATE WATER COLLECTION BY THE UNDERDRAIN WHILE ALSO INCREASING THE WATER STORAGE OF THE SYSTEM. THE AGGREGATE SIZING SHOULD BE CONSISTENT WITH AASHTO M43, WITH A NOMINAL DIAMETER OF 1.5 INCHES. ALL AGGREGATE STONE IS TO BE WASHED TO MINIMIZE THE INTRODUCTION OF FINES INTO THE SYSTEM.
- THE CLEAN OUT PIPE IS INTENDED TO PROVIDE MAINTENANCE ACCESS TO UNCLOG THE UNDERDRAIN PIPE SHOULD IT BECOME CLOGGED. THE MINIMUM PIPE DIAMETER CONSIDERED SHOULD BE 6 INCHES. THE CLEAN OUT SHOULD BE INSTALLED LEVEL WITH THE FINISHED GRADE AND INCLUDE A THREADED CAP TO PREVENT WATER FROM LEAKING INTO THE PIPE.
- THE OVERFLOW STRUCTURE IS INTENDED TO PROVIDE DRAINAGE OF EXCESS WATER PAST THE DESIGN VOLUME. IT IS TO BE INSTALLED WITH A SLOTTED DOME OVERFLOW TO PREVENT TRASH AND DEBRIS FROM ENTERING THE UNDERDRAIN. THE SUM OF THE SLOT OPENING SIZES IN THE SLOTTED DOME OVERFLOW MUST BE GREATER THAN THE AREA OF THE OPEN PIPE. THE MINIMUM PIPE DIAMETER CONSIDERED SHOULD BE 6 INCHES.
- THE PVC UNDERDRAIN PIPE IS TO CONSIST OF A SLOTTED OR PERFORATED PIPE WRAPPED IN A NON-WOVEN FILTER FABRIC AND BE INSTALLED CONSISTENT WITH FDOT STANDARD PLANS INDEX 440-001.
- AN IMPERMEABLE LINER AND A ROOT RATED BARRIER IS TO BE INSTALLED TO PROTECT STRUCTURES FROM ROOT AND WATER DAMAGE. A NON-WOVEN FILTER FABRIC IS RECOMMENDED TO BE INSTALLED ON EITHER SIDE OF THE MEMBRANE TO PROTECT IT FROM PUNCTURE OR DAMAGE. THESE SHOULD BE INSTALLED PER MANUFACTURER INSTRUCTIONS.

INFILTRATION PLANTER BOX WITH SHALLOW GROUNDWATER TABLE

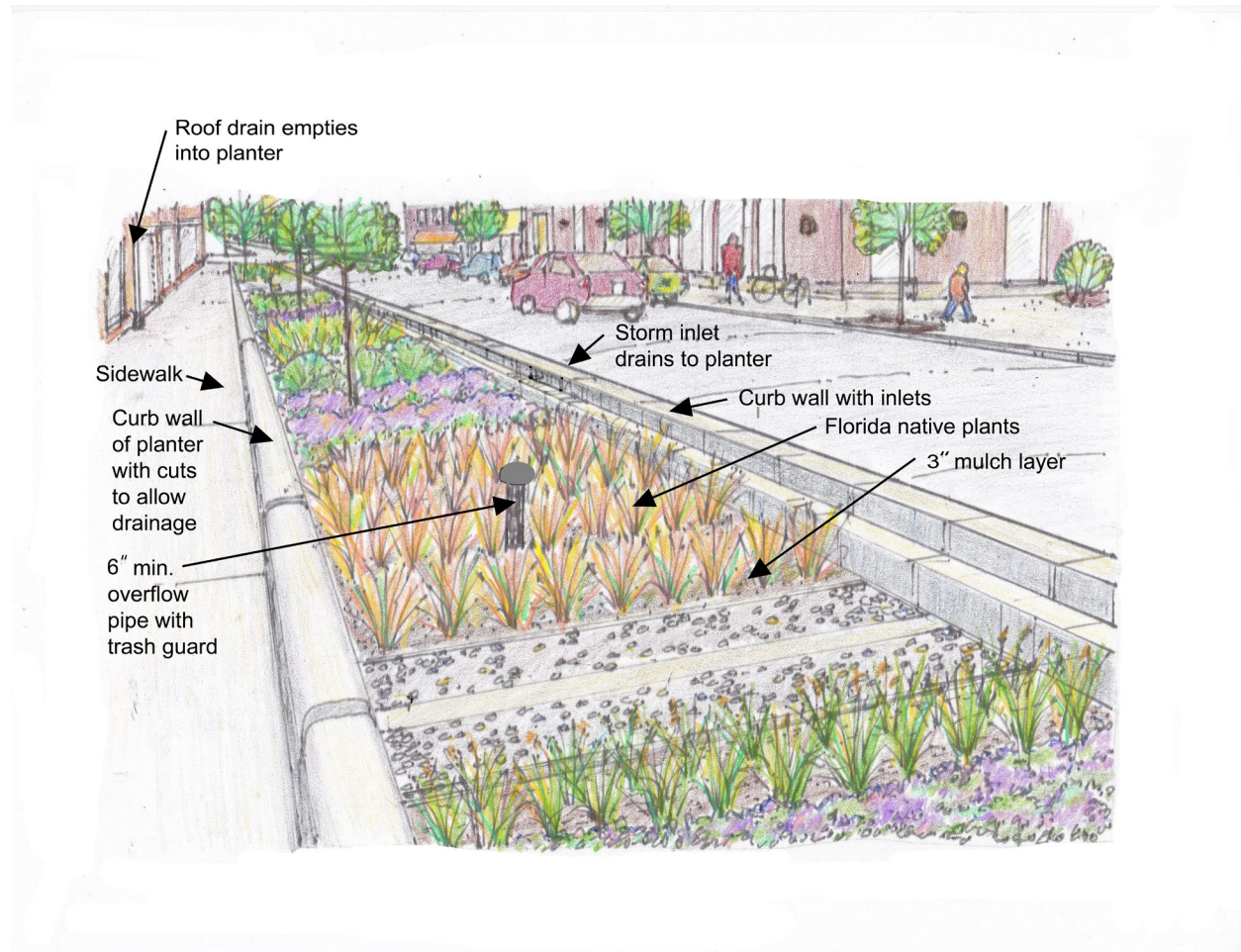
LID MANUAL DETAILS

ORANGE COUNTY; FLORIDA



## 4.8 Artist Renderings

Presented below is an artist rendering of how this practice may look incorporated into the urban landscape (**Figure 4-3**).



**Figure 4-3: Infiltration Planter Box in an Urban Landscape Setting (Alliance Design & Construction, Inc.)**

## 4.9 Inspection, Maintenance, and Monitoring

Operation of infiltration planter boxes requires adequate maintenance to ensure proper function. This includes frequent inspections to identify maintenance issues, performance monitoring, and general weeding/debris removal. This attachment provides detailed information on the operation and maintenance required to ensure proper function of infiltration planter boxes. This attachment also includes an inspection and maintenance checklist that goes over site conditions, various inspection items, and allows maintenance personnel to note if maintenance is needed and what corrective actions are recommended (**Appendix 4A** and **4D**). A flow chart is included to be used in tandem with the checklist, as it provides step by step action items to guide the maintenance personnel through the task (**Appendix 4B** and **4E**). The numbered items on the flow chart

correspond to the numbered items in the checklist. Additionally, optional monitoring guidance is provided in **Appendix 4C** and **4F**.

The maintenance personnel are required to take a minimum of five photographs as well as notes describing the conditions of the infiltration planter area. It is noted that five baseline photos should be taken of the infiltration planter box after construction is complete. Guidance on where the photos should be taken can be found at the end of **Appendix 4B** and **4E**. The notes should elaborate on any of the topics listed in the checklist but can also cover other observations made or actions taken that the maintenance personnel deems important. The maintenance checklists are required to be submitted annually to the County at an agreed upon date to ensure that the infiltration planter box is being regularly maintained. Every 5 years, a professional engineer must check the system to ensure that it is functioning as designed and sign off on its performance. An alternative maintenance plan and/or schedule may be used with approval from the County engineer.

#### **4.9.1 Inspection Steps and Checklists for Infiltration Planter Boxes without Underdrains**

This section provides steps, a checklist, and a flow chart for maintenance personnel to use while inspecting infiltration planter boxes. The checklist can be found in **Appendix 4A** and the flow chart can be found in **Appendix 4B**. A plan sheet for each site is to be included with every inspection sheet and it is encouraged that the maintenance personnel mark up the plan sheet as needed. Inspection includes the system surface, vegetation, and overall system performance. To aid the inspector during the maintenance process and in completing the checklist, the necessary inspection and maintenance activities are described below.

##### **4.9.1.1 Infiltration Planter Box Surface Activities**

Inspection of system surface activities includes inspecting the infiltration planter box for evidence of erosion, determining if the mulch layer is in place, and if the inflow and overflow points are free of debris. The below descriptions are intended to provide more detailed information on the specific action items for infiltration planter surface inspection noted in the check list.

**BS1:** Infiltration planter boxes should have all their surface areas inspected monthly for evidence of erosion. If there is evidence of erosion, such as rills or accumulation of sediments, the impacted areas should be restored and incorporation of erosion and sediment control products to protect against erosive forces should be considered. This can include stabilization practices such as rolled erosion control products, hard armoring, riprap, or the incorporation of additional vegetation to protect soils and slow the velocity of the incoming water.

**BS2:** Infiltration planter boxes mulch layer should be inspected monthly to determine if the mulch layer is still in place. If mulch has washed away, more mulch needs to be added until the desired depth (3 inches) is achieved. Mulch should be applied and raked to ensure even coverage. It is noted that mulch should be replaced in late winter before new growth sprouts. If mulch continues to get washed out, this could be indicative of a design issue that is failing to dissipate the velocity of water entering the system. Should this happen, it is recommended to examine how the system performs during a rainfall event to see how

water is entering the system and where some additional stabilization practices should be implemented to slow the velocity of the incoming water.

- BS3:** Infiltration planter boxes inflow and overflow points should be inspected monthly to determine if the inflow and overflow points are in working order. If riprap is used and is out of place or has debris in it, it should be replaced as designed and debris should be removed to ensure proper flow of incoming water.

#### 4.9.1.2 *Vegetation Management*

Inspection of vegetation management activities include inspecting the infiltration planter box for evidence of dead and/or unhealthy plants, that the plant community is still according to approved plans, and that the vegetation has a manicured look. The below descriptions are intended to provide more detailed information on the specific action items for infiltration planter vegetation management noted in the check list.

- VM1:** The vegetation in the infiltration planter box should be inspected monthly for dead and/or unhealthy plants. If present, the affected plants should be removed and replaced. If a particular plant type appears to not do well in a particular location, e.g., multiple plant replacements at a particular location, observations should be made to attempt to determine the reason for failure. Examples could be too much/not enough sunlight, too much/not enough water, or excessive erosive forces. If the plant is doing well in other areas of the infiltration planter box, observations of those locations should be made to see what is different from the problem location. New plant types from the appropriate plant lists included in this manual should be tried in the problem location until a successful variety is identified. The plants should also be inspected for evidence of pest infestations. Pest infestations should be treated using species specific natural control methods when possible, and chemical controls should be avoided.
- VM2:** The vegetation in the infiltration planter box should be inspected monthly to ensure that the plant community composition is still according to approved plans. As-built plans that include relevant design details should be provided to the maintenance crew. Additionally, a list of the plants in the infiltration planter box should be provided, including pictures of the plant at all stages of life (seedlings, juvenile, mature, dormant (if applicable)), as well as examples of healthy and not conditions. Signs of unacceptable water quality indicates that the system is not functioning as designed, along with unplanned growth of aquatic/wetland plants in the infiltration planter area. Plants that are not part of the intended plant list, such as weeds, invasive exotic plants, and nuisance species, are to be removed. Weeding should be done by hand, not with a power trimmer, and the plant should be pulled from the base of the plant, making sure to remove as much of the root ball as possible. New plants should be installed according to the original plant list if sufficient vegetative cover is not achieved.
- VM3:** The vegetation in the infiltration planter box should be inspected monthly to determine if the vegetation present has a manicured look, i.e., does it need to be pruned. Maintenance personnel are to prune, edge, weed, mow irrigate, and fertilize plants as needed to maintain a well-manicured look. Fertilization should be minimized to the extent practical and done

according to State and County rules when necessary. These practices are most frequently needed during the establishment period. Some grasses need cutting back during winter. Plants should be trimmed back if they are impeding pathways.

#### 4.9.1.3 System Performance

Inspection of the infiltration planter box surface activities include inspecting the infiltration planter box for evidence of standing water, debris, and/or sediment accumulation that may impact the performance of the infiltration planter box. The below descriptions are intended to provide more detailed information on the specific action items for infiltration planter box performance noted in the check list.

- SP1:** The infiltration planter boxes should be inspected monthly for evidence of standing water. Presence of wetland species can also be used as an indicator of extended ponding and saturated soils. If there is standing water, it is likely that one of the system layers are not functioning properly or are clogged. This can be due to several factors including accumulation of excess debris that can clog the system, compaction of the media layers, or long-term accumulation of fines along the growth media and mulch interface. Initial steps to address this issue should include removal of accumulated debris and sediments. Additionally, scarifying the growth media surface can increase infiltration capacity. If these steps fail to remedy the problem, some of the layers may need to be replaced to restore full function. It is recommended to try and identify which layer needs replacing rather than replacing the entire system. To do this, perform double ring infiltrometer testing at each layer by digging down to the interface of each layer and performing a test. Prevention of future accumulation of debris and sediments may necessitate pretreatment.
- SP2:** The infiltration planter boxes should be inspected monthly for evidence of debris and sediment accumulation. Debris and sediment accumulation should be removed using manual methods. Prevention of future accumulation of debris and sediments may necessitate pretreatment to prevent frequent clogging of media.

#### 4.9.2 Water Quality Performance Monitoring Guidance for Infiltration Planter Boxes without Underdrains

Understanding the true performance of infiltration planter boxes will require adequate monitoring to ensure proper characterization of the practice. Optional water quality monitoring guidance can be found in **Appendix 4C**.

#### 4.9.3 Inspection Steps and Checklists for Infiltration Planter Boxes with Underdrains

This section provides steps, a checklist, and a flow chart for maintenance personnel to use while inspecting infiltration planter boxes. The checklist can be found in **Appendix 4D**, and the flow chart can be found in **Appendix 4E**. A plan sheet for each site is to be included with every inspection sheet and it is encouraged that the maintenance personnel mark up the plan sheet as needed. Inspection includes the system surface, vegetation, and overall system performance. To aid the inspector during the maintenance process and in completing the checklist, the necessary inspection and maintenance activities are described below.

#### **4.9.3.1 Infiltration Planter Boxes Surface Activities**

Inspection of system surface activities includes inspecting the infiltration planter boxes for evidence of erosion, determining if the mulch layer is in place, and if the inflow and overflow points are free of debris. The below descriptions are intended to provide more detailed information on the specific action items for infiltration planter surface inspection noted in the check list.

- BS1:** Infiltration planter boxes should have all their surface areas inspected monthly for evidence of erosion. If there is evidence of erosion, such as rills or accumulation of sediments, the impacted areas should be restored and incorporation of erosion and sediment control products to protect against erosive forces should be considered. This can include stabilization practices such as rolled erosion control products, hard armoring, riprap, or the incorporation of additional vegetation to protect soils and slow the velocity of the incoming water.
- BS2:** Infiltration planter boxes mulch layer should be inspected monthly to determine if the mulch layer is still in place. If mulch has washed away, more mulch needs to be added until the desired depth (3 inches) is achieved. Mulch should be applied and raked to ensure even coverage. It is noted that mulch should be replaced in late winter before new growth sprouts. If mulch continues to get washed out, this could be indicative of a design issue that is failing to dissipate the velocity of water entering the system. Should this happen, it is recommended to examine how the system performs during a rainfall event to see how water is entering the system and where some additional stabilization practices should be implemented to slow the velocity of the incoming water.
- BS3:** Infiltration planter boxes inflow and overflow points should be inspected monthly to determine if the inflow and overflow points are in working order. If riprap is used and is out of place or has debris in it, it should be replaced as intended and debris should be removed to ensure proper flow of incoming water. All underdrain pipes should be flushed and/or vacuumed once a year to ensure proper inflow and outflow of water.

#### **4.9.3.2 Vegetation Management**

Inspection of vegetation management activities include inspecting the infiltration planter boxes for evidence of dead and/or unhealthy plants, that the plant community is still according to approved plans, and that the vegetation has a manicured look. The below descriptions are intended to provide more detailed information on the specific action items for infiltration planter vegetation management noted in the check list.

- VM1:** The vegetation in the infiltration planter boxes should be inspected monthly for dead and/or unhealthy plants. If present, the affected plants should be removed and replaced. If a particular plant type appears to not do well in a particular location, e.g., multiple plant replacements at a particular location, observations should be made to attempt to determine the reason for failure. Examples could be too much/not enough sunlight, too much/not enough water, or excessive erosive forces. If the plant is doing well in other areas of the infiltration planter boxes, observations of those locations should be made to see what is different from the problem location. New plant types from the appropriate plant lists

included in this manual should be tried in the problem location until a successful variety is identified. The plants should also be inspected for evidence of pest infestations. Pest infestations should be treated using species specific natural control methods when possible, and chemical controls should be avoided.

- VM2:** The vegetation in the infiltration planter boxes should be inspected monthly to ensure that the plant community composition is still according to approved plans. As-built plans that include relevant design details should be provided to the maintenance crew. Additionally, a list of the plants in the infiltration planter boxes should be provided, including pictures of the plant at all stages of life (seedlings, juvenile, mature, dormant (if applicable)), as well as examples of healthy and not conditions. Signs of unacceptable water quality indicates that the system is not functioning as designed, along with unplanned growth of aquatic/wetland plants in the infiltration planter area. Plants that are not part of the intended plant list, such as weeds, invasive exotic plants, and nuisance species, are to be removed. Weeding should be done by hand, not with a power trimmer, and the plant should be pulled from the base of the plant, making sure to remove as much of the root ball as possible. New plants should be installed according to the original plant list if sufficient vegetative cover is not achieved.
- VM3:** The vegetation in the infiltration planter boxes should be inspected monthly to determine if the vegetation present has a manicured look, i.e., does it need to be pruned. Maintenance personnel are to prune, edge, weed, mow irrigate, and fertilize plants as needed to maintain a well-manicured look. Fertilization should be minimized to the extent practical and done according to State and County rules when necessary. These practices are most frequently needed during the establishment period. Some grasses need cutting back during winter. Plants should be trimmed back if they are impeding pathways.

#### 4.9.3.3 System Performance

Inspection of the infiltration planter boxes surface activities include inspecting the infiltration planter boxes for evidence of standing water, debris, and/or sediment accumulation that may impact the performance of the infiltration planter boxes. The below descriptions are intended to provide more detailed information on the specific action items for infiltration planter boxes performance noted in the check list.

- SP1:** The infiltration planter boxes should be inspected monthly for evidence of standing water. Presence of wetland species can also be used as an indicator of extended ponding and saturated soils. If there is standing water, it is likely that one of the system layers are not functioning properly or are clogged. This can be due to several factors including accumulation of excess debris that can clog the system, compaction of the media layers, or long-term accumulation of fines along the growth media and mulch interface. Initial steps to address this issue should include removal of accumulated debris and sediments. Additionally, scarifying the growth media surface can increase infiltration capacity. All underdrain pipes in the system should be flushed and/or vacuumed once a year to prevent sediment buildup and clogging. If these steps fail to remedy the problem, some of the layers may need to be replaced to restore full function. It is recommended to try and identify which layer needs replacing rather than replacing the entire system. To do this,

perform double ring infiltrometer testing at each layer by digging down to the interface of each layer and performing a test. Prevention of future accumulation of debris and sediments may necessitate pretreatment.

**SP2:** The infiltration planter boxes should be inspected monthly for evidence of debris and sediment accumulation. Debris and sediment accumulation should be removed using manual methods and pipes should be flushed to prevent future accumulation and clogging. Prevention of future accumulation of debris and sediments may necessitate pretreatment to prevent frequent clogging of media.

#### 4.9.4 Water Quality Performance Monitoring Guidance for Infiltration Planter Boxes with Underdrains

Understanding the true performance of infiltration planter boxes will require adequate monitoring to ensure proper characterization of the practice. Optional water quality monitoring guidance can be found in **Appendix 4F**.

### 4.10 Design Calculations Example for Well-Draining Sandy Soils

This example calculation examines a scenario with well-draining sandy soils, which would be representative of the western portion of the county where there is a greater occurrence of well-draining sandy soils with deep water tables. For this example, it is assumed that a 3-acre pasture site located within the boundaries of the SFWMD is to be developed into a high-density commercial site. Soil types are hydrologic soils group (HSG) A. The calculations presented below demonstrate how to design a infiltration planter boxes to achieve the required water quality treatment. It is noted that the following example calculation is for projects within special basins, which can be found in FAC 62-330.

The first step is to determine the required treatment volume per the water management district (WMD) and the County criteria. As this practice is an infiltration based practice, the water quality benefit would be associated with the volume of water infiltrated. Since this example scenario is located within the SFWMD boundary, the SFWMD criteria for dry retention is the relevant water quality criteria for this project. A summary of pre- and post- development conditions are presented below followed by details of the infiltration planter design, the required treatment volume, and the final size of the system.

- Site conditions summary
  - Pre-development conditions
    - Land use: 3-acre site, pasture
    - Soil types: HSG A
  - Post-development conditions
    - Land use:
      - 2.4-acre site high density commercial
      - 0.6 acre will be open space (**20% open space requirement**)
    - Soil types: HSG A



- Impervious areas:
  - Commercial area will be **60% impervious**
  - 1.8 acres will be impervious
- Proposed LID practice summary
  - Proposed infiltration planter boxes is to have the following media layers:
    - 2 inch #89 stone
    - 6 inch #57 stone
    - 2 inch #89 stone
    - 2 inch coarse sand
    - 12 inch BAM (optional)
    - 3 inch hard mulch layer
    - Florida Friendly Landscaping
  - Since groundwater table and soils are not an issue at this site, no underdrain is proposed
- Determination of required treatment volume
  - As previously stated, the proposed system is a dry retention practice. Based on the SFWMD ERP handbook vol. 2 (SFWMD, 2016), the water quality treatment volume is 50% of either a) 1 inch of runoff from the developed site or b) 2.5 inches of runoff from the impervious area; whichever is greater.
    - a):  $\frac{3 \text{ ac} (1 \text{ in})}{12 \text{ in/ft}} = 0.25 \text{ ac} - \text{ft} \div 2 = 0.125 \text{ ac} - \text{ft}$
    - b):  $\frac{1.8 \text{ ac} (1.25 \text{ in})}{12 \text{ in/ft}} = 0.375 \text{ ac} - \text{ft} \div 2 = 0.1875 \text{ ac} - \text{ft}$
    - Since the 2.5 inch of runoff produces the greater treatment volume, this is the value required by the SFWMD
  - Per the current state special basin criteria, as listed in FAC 62-330, water quality standard, an additional 50% treatment volume is required. This is calculated as:
    - $0.1875 \text{ ac} - \text{ft} * 1.5 = 0.281 \text{ ac} - \text{ft}$
    - Therefore, the total treatment volume required for this project is 0.281 acre-feet
- Based on the above water quality treatment volume determination, the infiltration planter boxes must provide 0.281 acre-feet of storage. Sizing of the infiltration planter boxes is an iterative process where an initial area is assumed and based on the standard section of the proposed system, a provided volume can be determined. This is achieved easiest using a spreadsheet so values can be quickly and easily changed until the treatment volume is achieved.
  - Specifically, each aggregate layer is multiplied by the depth, area, and porosity to determine the water volume provided
  - The ponding volume is determined using the methods presented in **Section 4-2**, above
  - Following this process, a total area of 0.15 acres was determined.

- Based on this, an infiltration planter box system with a 2 inch of #89 stone, 6 inch of #57 stone, 2 inch #89 stone, 2 inch coarse sand layer, 12 inch BAM, and 3 inch mulch layer would need to be 0.15 acres to provide sufficient treatment for a 3 acre high intensity commercial site.
  - It is noted that the example problem sizing of the infiltration planter boxes is only for pollutant treatment purposes, not for flood control purposes. However, the infiltration planter boxes will provide some flood control, resulting in a smaller pond needed for flood control elsewhere on the site.

#### 4.11 Design Calculations Example for Poor-Draining / High Water Table Soils or Sensitive Groundwater Areas

This example calculation examines a scenario with poorly-drained sandy soils, which would be representative of the eastern portion of the county where there is a greater occurrence of poorly-drained sandy soils with shallow water tables. For this example, it is assumed that a 3-acre pasture site located within the boundaries of the SFWMD is to be developed into a high-density commercial site. Soil types are dual-hydrologic soils group (HSG) A/D. The calculations presented below demonstrate how to design an infiltration planter boxes in high groundwater conditions to achieve the required water quality treatment. It is noted that the following example calculation is for projects within special basins, which can be found in FAC 62-330.

The first step is to determine the required treatment volume per the water management district (WMD) and the County criteria. As this practice is a dry detention based practice, the water quality benefit would be associated with the volume of water that is captured and filtered through the BAM enhanced system. Since this example scenario is located within the SFWMD boundary, the SFWMD criteria for dry retention is the relevant water quality criteria for this project. A summary of pre- and post- development conditions are presented below followed by details of the infiltration planter design, the required treatment volume, and the final size of the system.

- Site conditions summary
  - Pre-development conditions
    - Land use: 3-acre site, pasture
    - Soil types: HSG A/D
  - Post-development conditions
    - Land use:
      - 2.4-acre site high density commercial
      - 0.6 acre will be open space (**20% open space requirement**)
    - Soil types: HSG A/D
    - Impervious areas:
      - Commercial area will be **60% impervious**
      - 1.8 acres will be impervious
- Proposed LID practice summary
  - Proposed infiltration planter box is to have the following media layers:

- 8 inch #57 stone
  - 2 inch #89 stone
  - 2 inch coarse sand
  - 12 inch BAM
  - 6 inch growth media
  - 3 inch hard mulch layer
  - Florida Friendly Landscaping
- Since groundwater table and soils are not an appropriate for infiltration at this site, a perforated underdrain with 6 inch diameter is proposed to facilitate system recovery
- Determination of required treatment volume
  - As previously stated, the proposed system is a dry detention practice. Based on the SFWMD ERP handbook vol. 2 (SFWMD, 2016), the water quality treatment volume is either a) 1 inch of runoff or b) 2.5 inches of runoff from the impervious area; whichever is greater.
    - a):  $\frac{3 \text{ ac} (1 \text{ in})}{12 \text{ in/ft}} = 0.25 \text{ ac} - \text{ft}$
    - b): 2.5 inches over the impervious area:  $\frac{1.8 \text{ ac} (2.5 \text{ in})}{12 \text{ in/ft}} = 0.375 \text{ ac} - \text{ft}$
    - Since the 2.5 inches of runoff over the impervious area produces the greater treatment volume, this is the value required by the SFWMD
  - Per the current state special basin criteria, as listed in FAC 62-330, water quality standard, an additional 50% treatment volume is required. This is calculated as:
    - $0.375 \text{ ac} - \text{ft} * 1.5 = 0.5625 \text{ ac} - \text{ft}$
    - Therefore, the total treatment volume required for this project is 0.5625 acre-feet
- Based on the above water quality treatment volume determination, the infiltration planter boxes must provide 0.5625 acre-feet of storage. Sizing of the infiltration planter boxes is an iterative process where an initial area is assumed, and based on the standard section of the proposed system, a provided volume can be determined. This is achieved easiest using a spreadsheet so values can be quickly and easily changed until the treatment volume is achieved.
  - Specifically, each aggregate layer is multiplied by the depth, area, and porosity to determine the water volume provided
  - The ponding volume is determined using the methods presented in **Section 4-2**, above
  - Following this process, a total area of 0.34 acres was determined.
- Based on this, an infiltration planter box with a 8 inch #57 stone layer, 2 inch #89 stone layer, 2 inch coarse sand layer, 12 inch BAM layer, 6 inch growth media layer, and 3 inch mulch layer would need to be 0.34 acres to provide sufficient treatment for a 3 acre high intensity commercial site.

- It is noted that the example problem sizing of the infiltration planter boxes is only for pollutant treatment purposes, not for flood control purposes. However, the infiltration planter boxes will provide some flood control, resulting in a smaller pond needed for flood control elsewhere on the site
- Since this system has an underdrain, the capacity of the underdrain pipe must be checked to ensure that the pipe can convey the design flow rates. This can be readily calculated using a modified form of the Manning's Equation:

$$d_i = \left( \frac{1630 Q_p n}{\sqrt{S}} \right)^{\frac{3}{8}}$$

where:  $d_i$  = Inside pipe diameter (in)  
 $n$  = Manning's coefficient of roughness  
 $Q_p$  = Peak design discharge rate (cfs)  
 $S$  = Slope of the pipe (ft/ft)

If the pipe cannot convey the peak flow rate, additional head losses must be considered in the recovery time, or a larger size pipe must be used.

## **REFERENCES**

1. Minnesota Stormwater Manual (2022). Soil water storage properties.  
[https://stormwater.pca.state.mn.us/index.php/Soil\\_water\\_storage\\_properties](https://stormwater.pca.state.mn.us/index.php/Soil_water_storage_properties)
2. Woessner, W.W. and Poeter, E. P. (2022). Hydrogeologic Properties of Earth Materials and Principles of Groundwater Flow. ISBN: 978-1-7770541-2-0. <https://gw-project.org/books/hydrogeologic-properties-of-earth-materials-and-principles-of-groundwater-flow/>
3. SFWMD (2016). Environmental Resource Permit Applicant’s Handbook Volume 2.  
[https://www.sfwmd.gov/sites/default/files/documents/swerp\\_applicants\\_handbook\\_vol\\_ii.pdf](https://www.sfwmd.gov/sites/default/files/documents/swerp_applicants_handbook_vol_ii.pdf)
4. SJRWMD (2018). Environmental Resource Permit Applicant’s Handbook Volume 2.  
<https://www.sjrwmd.com/static/permitting/PIM-20180601.pdf>

## **APPENDIX 4A**

# **Infiltration Planter Boxes without Underdrains Operation and Maintenance Checklist**

<b>Inspection and Maintenance Checklist for Infiltration Planter Boxes without Underdrains</b>			
Facility Name and Address:			
Date of Inspection:			
Site Conditions:                      Excellent <input type="checkbox"/> Good <input type="checkbox"/> Adequate <input type="checkbox"/> Poor <input type="checkbox"/>			
Date of Last Rain Event:			
Inspection Frequency Type:    Monthly <input type="checkbox"/> Quarterly <input type="checkbox"/> Annual <input type="checkbox"/>			
<b>Inspection Activities</b>			
Visual inspections are an integral part of system maintenance. Inspection includes monitoring for drainage, debris and sediment accumulation, vegetation health and coverage, and surface deterioration.			
Inspection Item	Checked (Y/N)	Maintenance Needed (Y/N)	Corrective Action/Comments
<b>INFILTRATION PLANTER SURFACE (Frequency – Monthly)</b>			
BS1. Evidence of erosion (i.e., visible rills or sediment accumulation)			
BS2. Mulch layer is still in place (depth of at least 3 in)			
BS3. Inflow and overflow points in working order			
<b>VEGETATION MANAGEMENT (Frequency – Quarterly)</b>			
VM1. Evidence of dead or unhealthy plants			
VM2. Is plant community composition still according to approved plans?			
VM3. Do plants appear well maintained/manicured			

<b>SYSTEM PERFORMANCE (Frequency – Monthly)</b>			
SP1. Evidence of standing water			
SP2. Debris and sediment accumulation			
<b>OVERALL CONDITION OF FACILITY</b>			
In accordance with approved design plans? (Y/N)			
Maintenance required as result of deficiencies detailed above? (Y/N)			
Date by which maintenance must be completed: (Y/N)			
<b>NOTES</b>			



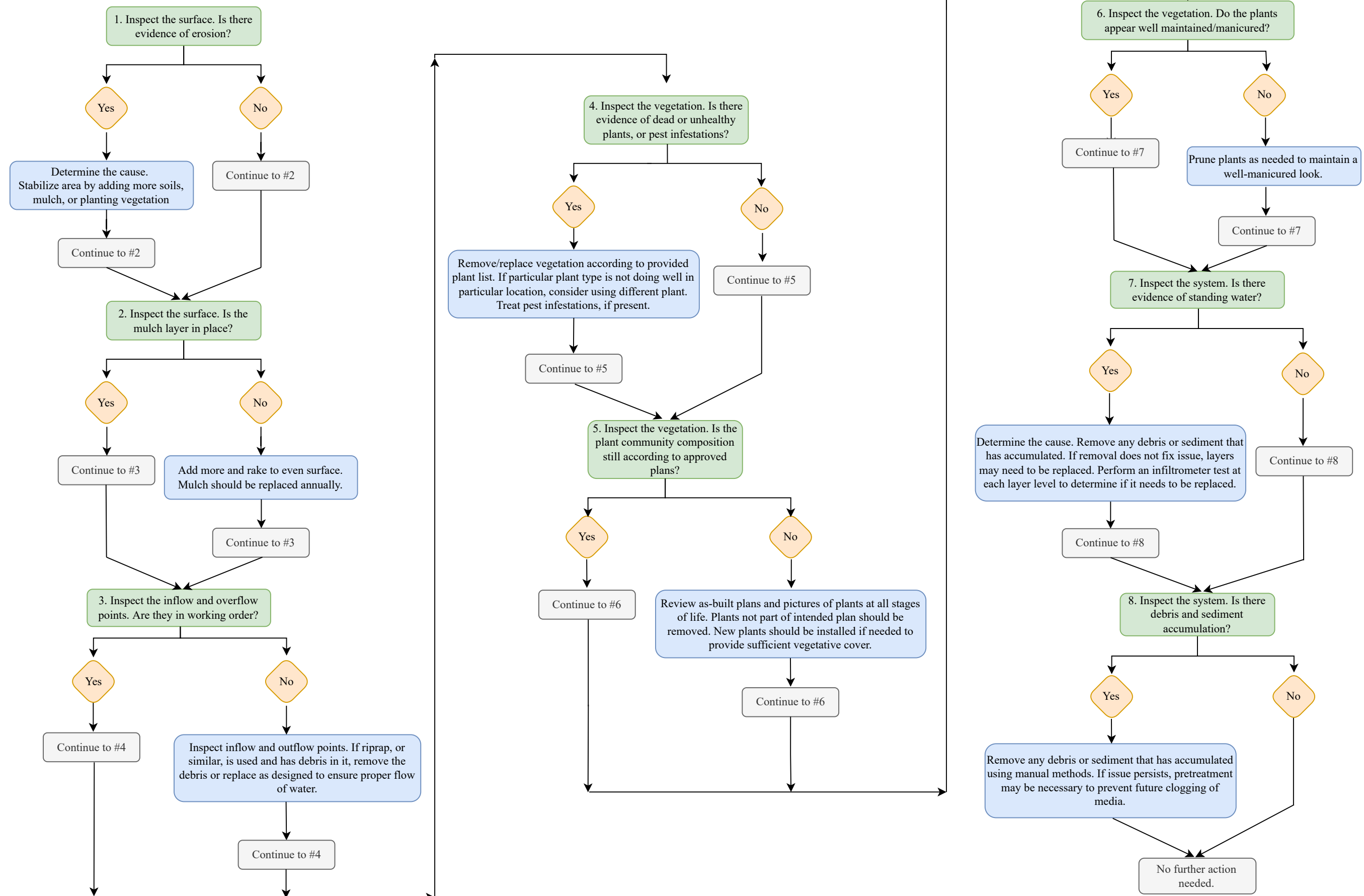
CERTIFICATION SIGNATURE	
Company Name:	
Company email, address, and phone number:	
Name of Inspector:	
Inspector Signature:	

Note: Take a minimum of 5 representative photos of the infiltration planter box area, attach the photos to the form, and include any additional observations in the notes section prior to submission. Make sure to include pictures of any inflow/outflow points, the vegetation, and any other aspects of the infiltration planter boxes.

## **APPENDIX 4B**

# **Infiltration Planter Boxes without Underdrains Operation and Maintenance Flow Chart**

# Infiltration Planter Boxes without Underdrain Operation and Maintenance



## **APPENDIX 4C**

# **Infiltration Planter Boxes without Underdrains Water Quality Performance Monitoring Guidance**

## **Water Quality Performance Monitoring**

This includes sampling water at key locations within the infiltration planter boxes as well as accumulated sediment and debris removed as part of maintenance activities. To properly monitor this LID practice the pollutant flow path, removal mechanisms, and the downstream waterbody of interest needs to be identified. To aid in the design of a proper infiltration planter box monitoring program, the general steps below can be followed. It is noted that the below sampling recommendations are relevant for an infiltration planter box that is installed in a region with a deep groundwater table.

Define the treatment objective and the downstream waterbody of interest. Specifically, determine the water quality parameter(s) of interest and if the goal is to reduce loading to a surface waterbody or groundwater. This will dictate how the practice should be monitored.

- o. If the waterbody of interest is a surface water, then the bulk of the water quality benefit is associated with the volume reduction provided by the practice. Thus, monitoring should focus on characterization of the flow and parameter EMCs of water at the system locations specified below.
  - i. The system inflow
  - ii. The system overflow
- p. Additionally, nutrients and other pollutants can be removed from the system in the form of maintenance activities that are performed, e.g., removal of vegetation, removal of sediments, removal of organic debris. Thus, the mass of pollutants associated with the following should also be characterized.
  - i. Accumulated sediments and organic debris
  - ii. Removed vegetation
- q. If the waterbody of interest is the groundwater, then, in addition to monitoring the inflow to the infiltration planter boxes, sampling of the water entering the ground should also be performed.
  - i. To sample water as it enters the ground, a lysimeter is to be installed in the infiltration planter boxes so that it can be sampled. Guidance on how to construct and install a lysimeter can be found here: <https://edis.ifas.ufl.edu/publication/AE554>. The sizing of the lysimeter should be based on the desired sample volume so that the lysimeter can hold the anticipated volume.
- r. Flow monitoring should be performed using an area-velocity probe, or other equipment appropriate for continuous estimation of flow, such as the ISCO 2150 area velocity probe.

- s. Stormwater sampling should be performed using auto-sampler equipment capable of collecting time- or flow-weighted composite samples, including but not limited to ISCO 6712 autosamplers. It is noted that, if possible, refrigerated autosamplers are preferred as they are able to preserve samples quicker than field personnel can collect samples.
- t. Storm events that are typical of Central Florida weather are to be sampled to evaluate typical performance of infiltration planter box. A rain gauge is to be installed onsite to measure rainfall at the site.
- u. System performance can be determined as the mass that is retained or removed from the infiltration planter box. This is determined as the difference in the mass entering the system and the mass leaving the system.
  - i. The mass entering the system can be determined based on the flow and constituent EMC. It is noted that while autosamplers are effective at characterizing the fine particulates and dissolved pollutants in stormwater, they are not effective at capturing coarser sediments and organic material. As such, when such materials are removed from infiltration planter boxes as part of maintenance activities, the mass of constituent associated with these activities must be considered as part of the loading to the system as well as loading removed from the system.
  - ii. One mass output is the mass leaving as surface runoff. This can be determined based on the overflow volume and constituent EMC.
  - iii. Another mass output is the mass of pollutants associated with removal of debris, sediments, or vegetation due to maintenance activities performed on the infiltration planter box. This can be determined based on the mass of material, constituent content, and moisture content of materials removed.
  - iv. The mass leaving to the groundwater can be determined based on the difference in inflow and overflow volume, and the constituent EMC as measured from the lysimeter.
  - v. The performance of the system can be determined based on the difference between the mass entering the infiltration planter box and the mass discharged to the downstream waterbody of interest.

## **APPENDIX 4D**

# **Infiltration Planter Boxes with Underdrains Operation and Maintenance Checklist**

<b>Inspection and Maintenance Checklist for Infiltration Planter Boxes with Underdrains</b>			
Facility Name and Address:			
Date of Inspection:			
Site Conditions:                      Excellent <input type="checkbox"/> Good <input type="checkbox"/> Adequate <input type="checkbox"/> Poor <input type="checkbox"/>			
Date of Last Rain Event:			
Inspection Frequency Type:    Monthly <input type="checkbox"/> Quarterly <input type="checkbox"/> Annual <input type="checkbox"/>			
<b>Inspection Activities</b>			
Visual inspections are an integral part of system maintenance. Inspection includes monitoring for drainage, debris and sediment accumulation, vegetation health and coverage, and surface deterioration.			
Inspection Item	Checked (Y/N)	Maintenance Needed (Y/N)	Corrective Action/Comments
<b>INFILTRATION PLANTER SURFACE (Frequency – Monthly)</b>			
BS1. Evidence of erosion (i.e., visible rills or sediment accumulation)			
BS2. Mulch layer is still in place (depth of at least 3 in)			
BS3. Inflow and overflow points in working order			
<b>VEGETATION MANAGEMENT (Frequency - Quarterly)</b>			
VM1. Evidence of dead or unhealthy plants			
VM2. Is plant community composition still according to approved plans?			
VM3. Do plants appear well maintained/manicured			



<b>SYSTEM PERFORMANCE (Frequency – Monthly)</b>			
SP1. Evidence of standing water, flushing/vacuuming pipes			
SP2. Debris and sediment accumulation			
<b>OVERALL CONDITION OF FACILITY</b>			
In accordance with approved design plans? (Y/N)			
Maintenance required as result of deficiencies detailed above? (Y/N)			
Date by which maintenance must be completed: (Y/N)			
<b>NOTES</b>			

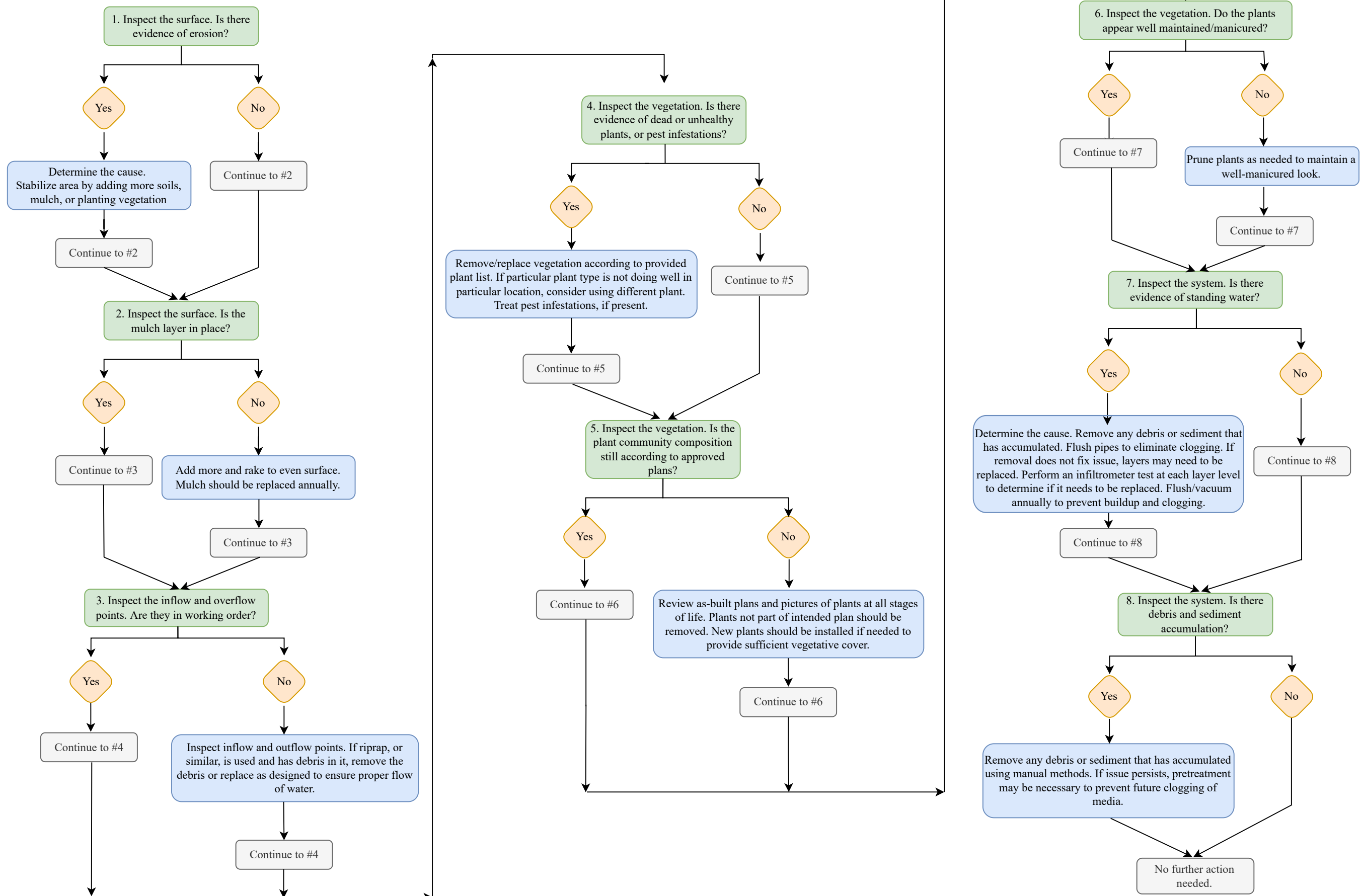
CERTIFICATION SIGNATURE	
Company Name:	
Company email, address, and phone number:	
Name of Inspector:	
Inspector Signature:	

Note: Take a minimum of 5 representative photos of the infiltration planter box area, attach the photos to the form, and include any additional observations in the notes section prior to submission. Make sure to include pictures of any inflow/outflow points, the vegetation, and any other aspects of the infiltration planter boxes.

## **APPENDIX 4E**

# **Infiltration Planter Boxes with Underdrains Operation and Maintenance Flow Chart**

# Infiltration Planter Boxes with Underdrain Operation and Maintenance



## **APPENDIX 4F**

# **Infiltration Planter Boxes with Underdrains Water Quality Performance Monitoring Guidance**

## **Water Quality Performance Monitoring**

This includes sampling water at key locations within the infiltration planter box as well as accumulated sediment and debris removed as part of maintenance activities. To properly monitor this LID practice the pollutant flow path, removal mechanisms, and the downstream waterbody of interest needs to be identified. To aid in the design of a proper infiltration planter box monitoring program, the general steps below can be followed. It is noted that the below sampling recommendations are relevant for an infiltration planter box that is installed in a region with a seasonal high groundwater table.

Define the treatment objective and the downstream waterbody of interest. Specifically, determine the water quality parameter(s) of interest and if the goal is to reduce loading to a surface waterbody or groundwater. This will dictate how the practice should be monitored.

- a. If the waterbody of interest is a surface water, then the bulk of the water quality benefit is associated with the volume reduction provided by the practice. Thus, monitoring should focus on characterization of the flow and parameter EMCs of water at the system locations specified below.
  - i. The system inflow
  - ii. The system overflow
- b. Additionally, nutrients and other pollutants can be removed from the system in the form of maintenance activities that are performed, e.g., removal of vegetation, removal of sediments, removal of organic debris. Thus, the mass of pollutants associated with the following should also be characterized.
  - i. Accumulated sediments and organic debris
  - ii. Removed vegetation
- c. If the waterbody of interest is the groundwater, then, in addition to monitoring the inflow to the infiltration planter box, sampling of the water entering the ground should also be performed.
  - i. To sample water as it enters the ground, a lysimeter is to be installed in the infiltration planter box so that it can be sampled. Guidance on how to construct and install a lysimeter can be found here: <https://edis.ifas.ufl.edu/publication/AE554>. The sizing of the lysimeter should be based on the desired sample volume so that the lysimeter can hold the anticipated volume.
- d. Flow monitoring should be performed using an area-velocity probe, or other equipment appropriate for continuous estimation of flow, such as the ISCO 2150 area velocity probe.

- e. Stormwater sampling should be performed using auto-sampler equipment capable of collecting time- or flow-weighted composite samples, including but not limited to ISCO 6712 autosamplers. It is noted that, if possible, refrigerated autosamplers are preferred as they are able to preserve samples quicker than field personnel can collect samples.
- f. Storm events that are typical of Central Florida weather are to be sampled to evaluate typical performance of infiltration planter boxes. A rain gauge is to be installed onsite to measure rainfall at the site.
- g. System performance can be determined as the mass that is retained or removed from the infiltration planter box. This is determined as the difference in the mass entering the system and the mass leaving the system.
  - i. The mass entering the system can be determined based on the flow and constituent EMC. It is noted that while autosamplers are effective at characterizing the fine particulates and dissolved pollutants in stormwater, they are not effective at capturing coarser sediments and organic material. As such, when such materials are removed from infiltration planter boxes as part of maintenance activities, the mass of constituent associated with these activities must be considered as part of the loading to the system as well as loading removed from the system.
  - ii. One mass output is the mass leaving as surface runoff. This can be determined based on the overflow volume and constituent EMC.
  - iii. Another mass output is the mass of pollutants associated with removal of debris, sediments, or vegetation due to maintenance activities performed on the infiltration planter box. This can be determined based on the mass of material, constituent content, and moisture content of materials removed.
  - iv. The mass leaving to the groundwater can be determined based on the difference in inflow and overflow volume, and the constituent EMC as measured from the lysimeter.
  - v. The performance of the system can be determined based on the difference between the mass entering the infiltration planter box and the mass discharged to the downstream waterbody of interest.

# We are engineers, scientists and innovators

Geosyntec is a specialized consulting and engineering firm that works with private and public sector clients to address their new ventures and complex problems involving the environment, our natural resources, and our civil infrastructure. Geosyntec has a staff of over 1,900 engineers, scientists, and related technical and project support staff located in more than 90 offices throughout the U.S. and in Canada, Sweden, Spain, UAE, Australia, and the United Kingdom.

**Geosyntec**   
consultants

engineers | scientists | innovators

Offices in Principal Cities of the United States and Select International Locations

[www.geosyntec.com](http://www.geosyntec.com)